

J U N E 2 0 0 7

R E C E P T I O N 5 0
P R I C E L I S T

M A G N A
D E S I G N

General information

Table of Contents	2
Pricing, Delivery, Warranty	4
Terms and Conditions	5
Specifications	6
Finishes	7

How to layout R50

Configurations	9
-----------------------	---

Space planning with standard depth worksurfaces

Rectangular tops	14
Bow Front tops	15
Trapezoid tops	16

Ordering instructions

Desk	17
Desk TTOP	18
Desk return	19
Return RTOP	19
Curved Corner unit	20
Finishes to specify	20

Standard Depth desks

Rectangular, Bow Front, Trapezoid Desks	21
with IR Inside Radius on user side	22
with DIR Double Inside Radius on user side	23
Curved Corner units	24
R50 returns used with RTOP	25
R50 bridges used with RTOP	26
TTOP Transaction tops	27
Fillers and Accents	27
TTOP with US Standard locations	28
TTOP with UW Wide locations	29
RTOP with US Standard locations	30
RTOP with UW Wide locations	31

Deeper Desks

Rectangle worktops	32
Bow Front worktops	33
Trapezoid worktops	34

S50 Series 50 components

S50 bridges without RTOP	35
S50 credenzas without RTOP	36
s50 returns without RTOP	38

Transaction top and Desk top edges

Applied edge drawing	39
Transaction top larger wood edges	40
Transaction top inlays	40
Transaction top aluminum edges	40

Add pedestals or cabinets to desk or return

Options and Accessories	41
Fillers and Accent panels	27 and 41
R50 end panels, pedestals, cabinets, modesty panels	42

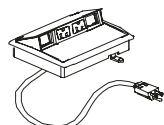
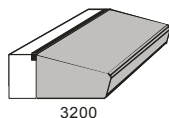
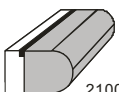
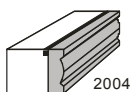
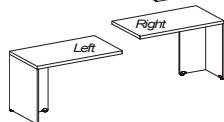
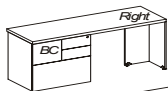
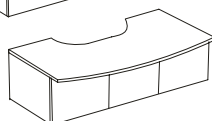
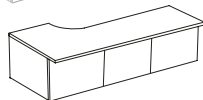
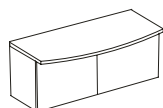
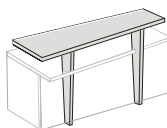
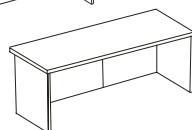
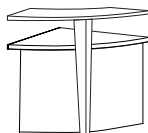
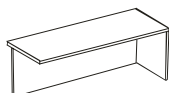
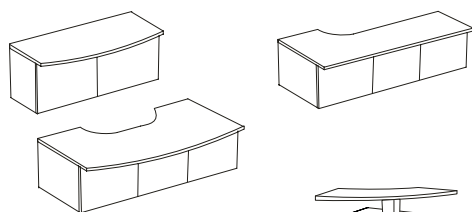
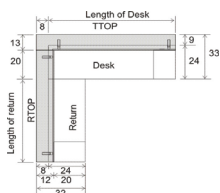
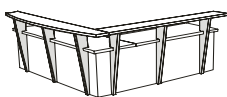

Pricing and Delivery information

PRICES:

Prices are subject to change without notice and the price list with the later date supersedes all previous price lists.
Prices do not include charges for cartoning, crating, installation, or inside delivery.
Cartoning or crating charges will be added to orders weighing under 250 lb.

DELIVERY:

All prices include delivery outside the Zone 1 region.

Zone 1 includes Washington, Oregon, Alaska, Hawaii, and British Columbia. Prices in Zone 1 reflect Factory Will Call. Zone 1 dealer discounts are adjusted accordingly.

A freight surcharge will be added to Zone 2 orders totaling less than \$10,000 LIST. The freight surcharge will be 10% of NET invoice total.

A fuel surcharge will be added to Zone 2 orders over \$10,000. This will vary depending upon on the fuel index that is published by the Energy Information Administration on the first Monday of each month and is used by the trucking industry to adjust their rates.

The surcharge will be waved on full truck loads to a single location with a net value of \$30,000 to the West region, \$45,000 Midwest region and \$60,000 East region.

For current fuel surcharges and for a map of regions, please visit our website at www.magnadesign.com.

Standard delivery will be made on a dock-to-dock basis or to a sidewalk. Should you have special requirements such as inside delivery or prior notification please contact Magna Design's traffic department. Special delivery requirements will be handled on an as-available basis and will likely result in additional charges.

All Shipments are FOB Magna Plant, Lynnwood, Washington.

MagnaCad



The MagnaCad graphic and specification package for Reception 50 layout drawings and 3D isometric illustrations is scheduled to be ready in late 2007.

Until then please contact customer service for current quotes and drawings.

Reception 50 product graphic and specification packages are available for use with 20-20 GIZA software, Data One's Design Express software and Project Matrix's Project Spec software. Software such as 20-20 GIZA, Design Express or Project Spec may be purchased directly from the software provider. Magna provides just the graphic and specification information for our product lines that can be used in these third party software products.

LIFETIME limited warranty

MAGNA DESIGN warrants that its products are free from defects in design, material, and workmanship under normal use and with proper care and maintenance. This warranty will remain in effect for the following period of time, commencing with the date of purchase from MAGNA DESIGN but only so long as the original purchaser continues to own the product:

WoodPlus2 finishes on products purchased January 2002 or later - **LIFETIME**

Drawer slides - **LIFETIME**

LIFETIME for ALL PRODUCT and COMPONENTS, not listed below

Healthcare products - **ten (10) years**

Electrical components and functional mechanisms, like keyboard trays - **five (5) years**

Wood finishes - **three (3) years**.

During the term of this Warranty, MAGNA DESIGN will repair or replace with the same or comparable product or part without charge any product or part that malfunctions or fails to conform to this Warranty. THIS REMEDY OF REPAIR OR REPLACEMENT IS PURCHASER'S SOLE AND EXCLUSIVE REMEDY WITH REGARD TO ANY PRODUCT DEFECT.

This Warranty does not apply to:

Any damage caused during shipment.

Any product installed or used other than in accordance with MAGNA DESIGN guidelines.

Any product that has been repaired, altered, or modified by any person other than MAGNA DESIGN.

Any attachment added to a product.

Any fabric or upholstery material.

Any part or material provided by Purchaser.

Any damage caused by misuse, abuse, or negligence on the part of Purchaser or any third party.

THERE ARE NO OTHER WARRANTIES, EITHER EXPRESSED OR IMPLIED, INCLUDING ANY WARRANTY OF MERCHANTABILITY OR OF FITNESS FOR A PARTICULAR PURPOSE. UNDER NO CIRCUMSTANCES WILL MAGNA DESIGN BE LIABLE FOR ANY CONSEQUENTIAL OR INCIDENTAL DAMAGES ARISING FROM ANY PRODUCT DEFECT.

This warranty is in effect for products shipped on or after May 1, 1998.

Terms and Conditions

QUOTATIONS:

Price quotations on non-catalog or special orders will not be valid after thirty (30) days without written approval from Magna Design, Inc.

CREDIT TERMS

Net thirty (30) days after invoice date upon credit approval.

ORDERING :

When ordering, please include complete identification and description of the product being ordered using Magna Design specifications and terminology. All orders must be in writing.

TELEPHONE ORDERS:

All telephone orders must be confirmed with a written purchase order.

ACKNOWLEDGMENTS:

All orders when accepted will be acknowledged by mail or email indicating the terms and conditions by which the order was accepted and a description of the items being ordered. Orders will be completed and shipped in accordance with the information on the acknowledgment. If the acknowledged information is incorrect we must receive written instruction to change.

CHANGE ORDERS:

Order entry will take place upon receipt of an ENTERABLE purchase order from an authorized Magna Design dealer.

Once the order has been entered, no changes are allowed on MAGNA NOW! orders.

For orders not on the MAGNA NOW! shipping program, order changes will be subject to a minimum \$25 processing fee. Actual change order charges may be higher depending on the status of the job at the time a change is made.

CANCELLATIONS:

If a cancellation is accepted, a 15% minimum restocking charge will be applied on cancellations of standard products.

Cancellations will not be accepted on special, modified or custom products.

RETURNED GOODS:

Returned merchandise will not be accepted for return without twenty (20) days prior written notice and written Returned Goods Authorization (RGA) from Magna. Returned goods will be subject to a minimum 15% restocking and refurbishing charge in addition to shipping costs. (See Warranty policy for defective goods.)

LEAD TIMES:

To current accounts with approved credit, Magna FLEX *enterable* orders will be made available (in standard finishes) within 4 to 6 weeks. All orders are subject to current inventories. Leadtimes may vary according to factory volume.

To current accounts with approved credit, Magna NOW! *enterable* orders in standard finishes will be made available 10 *working days* after receipt of *enterable* order. *Working day* = Monday through Friday except factory holidays.

Day 1 (of 10) starts upon receipt of *enterable* order before 2:00 PM Pacific Time.

Will Call orders will be ready at 2:00 PM of Day 10.

Leadtimes may vary according to factory volumes.

DELIVERY:

Orders will be delivered in accordance with the delivery dates indicated on the order acknowledgment and partial shipments may be made unless the order instructions indicate that an order must be shipped complete.

SHIPPING:

We reserve the right to use our own discretion in selecting routes and freight carriers. We will attempt to meet any special routing requirements that you may have but assume no liability for damages or costs incurred by our inability to do so.

STORAGE:

Storage charges will be charged on orders not accepted or picked up within five (5) days of acknowledged delivery dates unless we are notified thirty (30) days in advance. Storage will be charged at the rate of 2% for the first fifteen (15) days delay and 3% for each fifteen (15) day period thereafter.

FREIGHT CLAIMS:

Before signing a delivery receipt, make certain that goods are inspected for possible damage. If there is visual damage, record the extent of the damage on all copies of the bill of lading before signing. If there is no visual damage to goods that are cartoned or crated, we strongly suggest that the merchandise be unpacked and inspected immediately. If damages are discovered, save the packaging and contact the carrier immediately for inspection. Claims for damages should be filed with the delivering carrier and payment for the goods may not be withheld pending settlement of the carrier damage claims.

Magna assumes no liability for freight damage or the workmanship or cost of repairs made by others without prior written authorization. SPECIFICATIONS:

All published dimensions and weights are approximate and we assume no liability for errors or inaccuracies in product literature. We reserve the right to modify or change product design and/or delete product models without prior notice.

Reception 50 Specifications

The Reception 50 group is designed to offer a contemporary reception station design, shipped ready to assemble and provides a wide variety of configurations.

FINISHES:

We take great care in matching color and texture of materials in our product. However, it is impossible to guarantee exact matching in all cases.

SPECIFICATION HIGHLIGHTS

All exposed laminate surfaces shall be Magna WoodPlus laminate. Standard finishes shall include WoodPlus wood grain patterns as described in the finishes section. Pedestals, lateral files, hutches, overheads and end support panels are also available in ColorPlus laminates.

Edge Bands

Desk tops are 1.5" thick and are banded with 3mm PVC or 3mm hardwood.

Transaction tops are available in a wide variety of PVC or hardwood edges.

Drawer fronts and doors are banded with matching tape.

Tops and top edges

All Reception 50 tops are 1.5" thick. The three ply balanced construction consists of a 45 LB industrial board core surfaced with WoodPlus laminate and a balancing backer sheet.

Desks

Desks are designed with all the required top support as well as all required assembly hardware.

Each desk end requires a return, pedestal, cabinet or to be bracketed to the floor at each end to ensure stability.

Floor brackets are not included.

Transaction tops

Standard thickness is 1.5", except when specified edge profile requires 1.75" thick top.

Desk transaction tops are available in TT Rectangular, TZ Trapezoid or BO Bow Front shapes.

Curved corner transaction tops are available with TT Rectangular Desk transaction tops on both sides.

Return transaction tops are available in TT Rectangular shape.

All upright vertical supports are included with each Transaction Top.

Filler panels

Filler panels are available to fill the space between the transaction top and desk and between two vertical upright supports.

Grain runs vertically on filler panels. May be specified in a matching, complementary or contrasting finish including metal.

Accent panels

Accent panels are available to fit below the desktop and stop 6" above the floor and fit between the vertical upright supports.

Grain runs vertically on accent panels. May be specified in a matching, complementary or contrasting finish including metal.

Adjustable Glides

All free standing components are equipped with threaded stem adjustable glides. Glides are set in threaded inserts fitted in a PVC edge band for structural integrity.

Wire Management

Optional grommets are available. Finish is satin black.

Optional wiremanagers are available.

Worklight

All worklights are UL labeled and have a built in diffuser. Finish is black.

Finishes

Reception 50 components are available in WoodPlus finishes with a matching WPE WoodPlus wood grained PVC edge. Pedestals, cabinets and end support panels are also available in ColorPlus laminates.

Magna WoodPlus laminate finish consists of a unique combination of wood products and resins thermofused under high temperature and pressure into a single, wood grained or solid color structural panel. Work surfaces are WoodPlus high pressure. Panel edges are finished in matching PVC.

Cleaning and Care

WoodPlus / ColorPlus may be cleaned with mild cleaning agents that contain no abrasives, bleach or bleach substitutes.

Under no circumstances can acetone or polish remover be used to clean any of the surfaces. Using it will void the warranty on the product and can do considerable damage to the surface.

Reception 50 Finishes

Finishes

Please specify transaction top, worktop, lower verticals, upright supports, filler panels and accent panels for each workstation

WP04 Solar Oak	WP-33 Blossom Cherry ① ③	WP48 Sipping Seattle Java ③	WP75 Chestnut ①
WP05 Rift Oak ①	WP35 Golden Cherry ① ②	WP61 Pear	WP81 Fusion Maple
WP15 Midnight ① ② ③	WP-37 Mocha Cherry ① ②	WP-67 Chocolate Pear ① ②	CP76 Espresso ⑤
WP23 Cordovan	WP41 Natural Maple	WP71 Dark Cherry	CP88 Black ⑤
WP31 Medium Cherry	WP45 Anigre	WP73 Cognac	CP98 Slate ⑤

- ① WoodPlus XTRA finishes, upcharge of \$600 List per order for these finishes
- ② there is no matching WPE PVC edge for worktops or transaction tops in these finishes, please either choose another WPE edge or specify a matching STD wood edge and add \$106 list per worktop and transaction top
- ③ Hi-Brite is the worktop or transaction top surface texture, all other surfaces have a suede texture.
- ④ Hi-Lustre is the worktop or transaction top surface texture, all other surfaces have a suede texture
- ⑤ available only for vertical surfaces

Sheen on transaction tops and desktops

Standard Satin sheen is approximately 10% sheen.

Hi-Brite sheen is approximately 25% sheen.

Hi-Lustre sheen is approximately 35% sheen.

Hi-Lustre sheen is available on all transaction tops and desktops except for the Hi-Brite finishes.

Charge is \$600 List per order per finish.

Sheen on all other surfaces

Standard Satin sheen is approximately 10% sheen.

Please visit our website at www.magnadesign.com or call Customer Service at 800.233.2304 for the latest finish information

How to layout Reception 50 stations

Desk depth	For 'standard' depth		For 'deeper' depth	
	depth of top	with TTOP	depth of top	with TTOP
Rectangle desk top	24.00	33.00	27.00	36.00
Bow Front desk top	26.50	35.00	29.50	38.00
Trapezoid desk top	30.00	37.00	33.00	40.00

Note: both ends of each desk need to be secured with one of the following:

- return, either Reception 50 or Series 50
- pedestal, lateral file or combo cabinet
- bracketed to the floor - hardware supplied by installer

Step 1 Choose the desk - this will choose the size and shape of the main desk
As shown in Configuration R50-104 you may choose two or three desks that can be joined using the corner tops

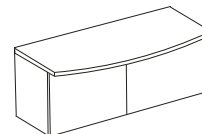

Step 2 Choose any returns that will support a transaction top
The returns have a rectangular top and connect directly to the desk from Step 1

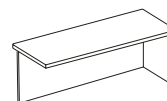

Step 3 Choose any corner tops and curved corner verticals if needed.
If you wish to add a curved corner transaction top, you need to include the curved corner WoodPlus vertical: R50-VERT-CRNR-WP

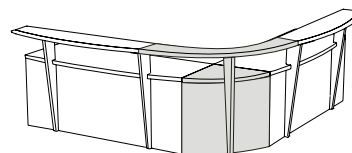

Step 4 Choose the pedestals, lateral files and combo cabinets
These provide the needed storage as well as the counterweight to the transaction tops.
At both ends of all units, one of the following is needed to stabilize the reception unit: pedestal, cabinet, desk, bridge or credenza.
If none are included, the end panel must be bracketed to the floor when installed. Brackets to attach the end panel to the floor are not included.

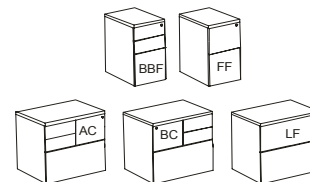

Step 5 Choose the transaction tops with the appropriate upright spacing for your needs
For desks choose the R50-TTOP-... models
For corners choose the R50-CTOP-.... Models
For returns choose the R50-RTOP-,,, models

The transaction tops with 'standard' upright spacing overhang up to 18" past the upright.

The transaction tops with 'wide' upright spacing are positioned within a few inches of the end of the transaction top. When used with the 'filler' panels between the transaction top and worktop, the 'wide' upright spacing provides more worktop privacy.

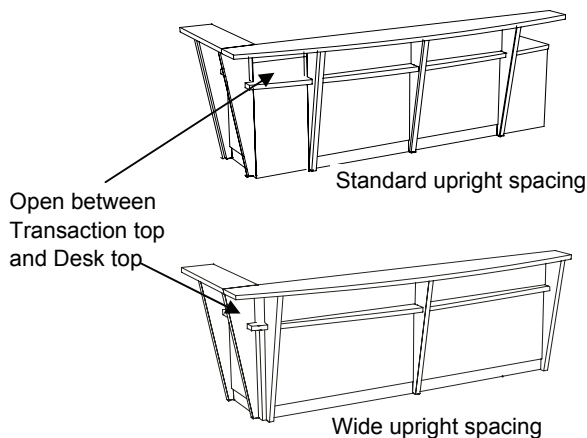

Step 6 Choose the filler panels and accent panels
Filler panels fit between the worktop and transaction top.
Accent panels are below the worktop and 6" above the floor.

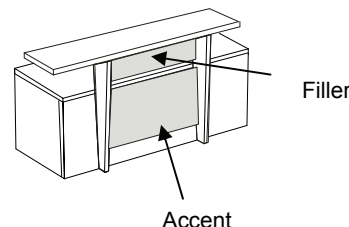

Step 7 Choose the transaction top and worktop edges and inlays

RECEPTION 50 CONFIGURATIONS

R50-101 Standard desk top depth

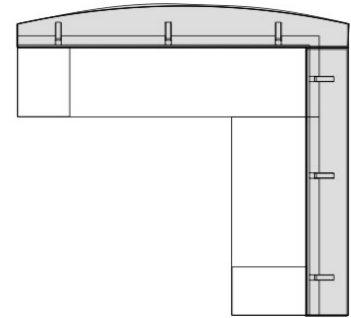
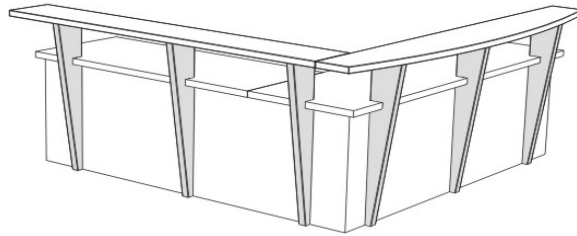

R50-101-90. Left Return

Overall footprint is 101" deep by 98" long
90" long desk with 66" long return. Return transaction top is 86" long.

Heavy
Wood edge
with inlay

Description	Model	Qty	WPE edge		Heavy Wood edge with inlay	
			List	Ext	List	Ext
Desk Rectangle top	R50-D-TT-249029-L	1	2,354	2,354	2,354	2,354
Bow front T Top	R50-TTOP-BO-159841-US3	1	1,747	1,747	1,747	1,747
Rectangular Return	R50-R-TT-246629-L	1	1,517	1,517	1,517	1,517
Rectangular Return T top	R50-RTOP-TT-138641-US3-L	1	1,257	1,257	1,257	1,257
T Top 3000 edge	R50-TTOP-1EDGE-3000-BOW	2			509	1,018
T Top Chrome inlay	R50-TTOP-INLAY1-CHROME-BOW	2			137	274
3mm wood edge	Standard 3mm wood edge	4			100	400
Add BBF ped to desk	R50-PED-BBF-ADD	1	444	444	444	444
Add 36" long lateral file to return	R50-CAB-LF-ADD	1	800	800	800	800
Jan 2007 list price total			8,119		9,811	

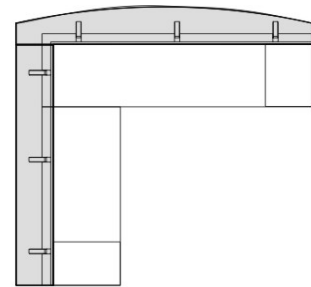
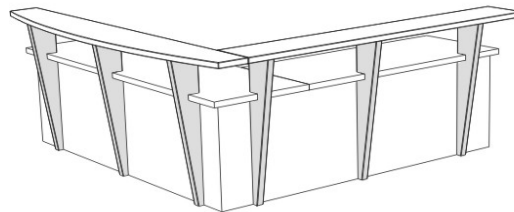

R50-101-90. Right Return

Overall footprint is 101" deep by 98" long
90" long desk with 66" long return. Return transaction top is 86" long.

Description	Model	Qty	List	Ext	List	Ext
Bow front T Top	R50-TTOP-BO-159841-US3	1	1,747	1,747	1,747	1,747
Rectangular Return	R50-R-TT-246629-R	1	1,517	1,517	1,517	1,517
Rectangular Return T top	R50-RTOP-TT-138641-US3-R	1	1,257	1,257	1,257	1,257
T Top 3000 edge	R50-TTOP-1EDGE-3000-BOW	2			509	1,018
T Top Chrome inlay	R50-TTOP-INLAY1-CHROME-BOW	2			137	274
3mm wood edge	Standard 3mm wood edge	4			100	400
Add BBF ped to desk	R50-PED-BBF-ADD	1	444	444	444	444
Add 36" long lateral file to return	R50-CAB-LF-ADD	1	800	800	800	800
Jan 2007 list price total			8,119		9,811	

RECEPTION 50 CONFIGURATIONS

R50-102 Standard desk top depth

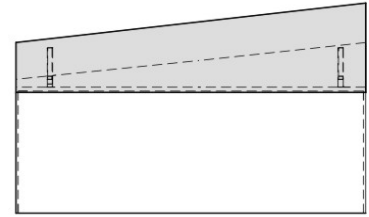
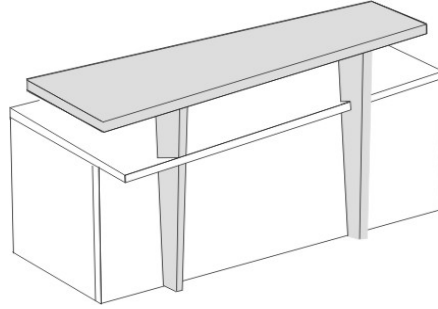

R50-102-84

**Overall footprint is 37" deep by 84" long
Desk is 84" long with trapezoid desk top and transaction top**

Description	Model	Qty	WPE edge		Heavy Wood edge with inlay		
			List	Ext	List	Ext	
Desk Trapezoid top	R50-D-TZ-308429-R	Right	1	2,440	2,440	2,440	2,440
Trapezoid T Top	R50-TTOP-TZ-178441-US2-R	Right	1	1,152	1,152	1,152	1,152
T Top 3000 edge	R50-TTOP-1EDGE-3000-TZ		1			509	509
T Top Chrome inlay	R50-TTOP-INLAY1-CHROME-TZ		1			137	137
3mm wood edge	Standard 3mm wood edge		2			100	200
Add BBF ped to desk	R50-PED-BBF-ADD		1	444	444	444	444
WoodPlus filler	R50-FILLER-WP		1	184	184		
Metal filler	R50-FILLER-METAL		1			444	444
Jan 2007 list price total				4,220		5,326	

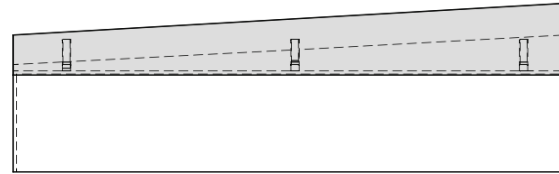
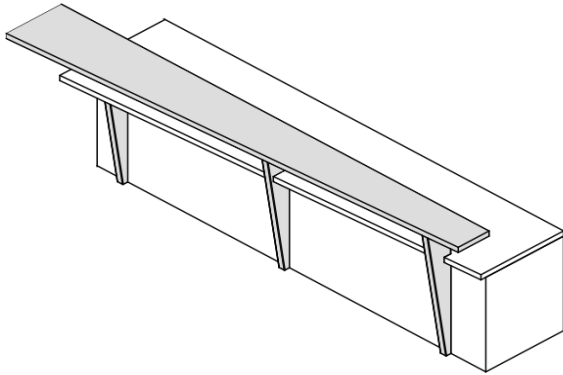

R50-102-120

**Overall footprint is 37" by 120"
120" long desks, Trapezoid desk top and transaction top**

Description	Model	Qty	WPE edge		Heavy Wood edge with inlay		
			List	Ext	List	Ext	
Desk Trapezoid top	R50-D-TZ-3012029-R	Right	1	3,175	3,175	3,175	3,175
Trapezoid T Top	R50-TTOP-TZ-1712041-US3-R	Right	1	1,631	1,631	1,631	1,631
T Top 3000 edge	R50-TTOP-1EDGE-3000-TZ		1			509	509
T Top Chrome inlay	R50-TTOP-INLAY1-CHROME-TZ		1			137	137
3mm wood edge	Standard 3mm wood edge		2			100	200
Add BBF ped to desk	R50-PED-BBF-ADD		1	444	444	444	444
WoodPlus filler	R50-FILLER-WP		2	184	368		
Metal filler	R50-FILLER-METAL		2			444	888
Jan 2007 list price total				5,618		6,984	

RECEPTION 50 CONFIGURATIONS

R50-103 Standard desk top depth

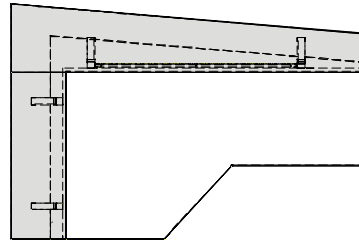
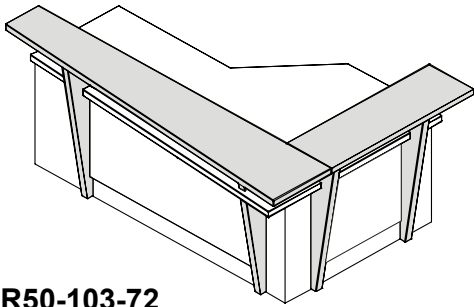

R50-103-72

Overall footprint is 55" by 80"

Desk top size is 48" x 72"

72" long desk, trapezoid, with inside angled top and return t top

Description	Model	Qty	WPE edge		Heavy Wood edge with inlay	
			List	Ext	List	Ext
Desk Trapezoid top	R50-D-TZ-487229-IR-L	1	2,811	2,811	2,811	2,811
Trapezoid T Top	R50-TTOP-TZ-178041-US2-L	1	1,152	1,152	1,152	1,152
Rectangle return T Top	R50-RTOP-TT-124241-US2-L	1	754	754	754	754
T Top 3000 edge	R50-TTOP-1EDGE-3000-TZ	2			509	1,018
T Top Chrome inlay	R50-TTOP-INLAY1-CHROME-TZ	2			137	274
3mm wood edge	Standard 3mm wood edge	3			100	300
Add BBF ped to each desk	R50-PED-BBF-ADD	1	444	444	444	444
Jan 2007 list price total			5,161		6,753	

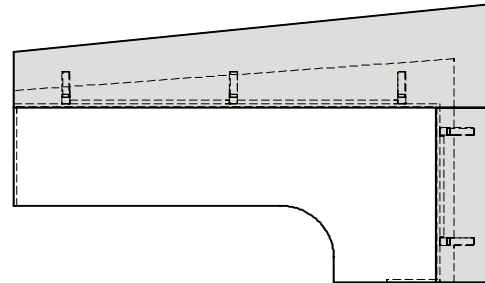
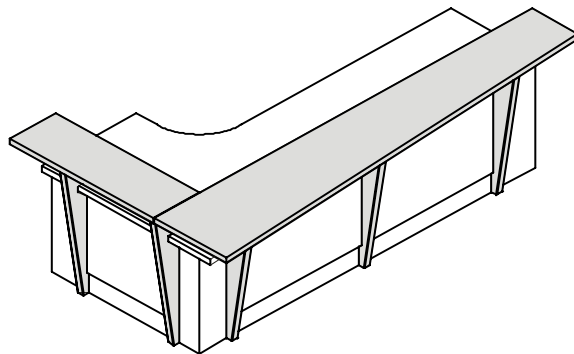

R50-103-123

Overall footprint is 55" by 128"

Desk top size is 48" x 120"

120" long desk, trapezoid, with inside radius top and return t top

Description	Model	Qty	WPE edge		Heavy Wood edge with inlay	
			List	Ext	List	Ext
Desk Trapezoid top	R50-D-TZ-4812029-IR-R	1	3,920	3,920	3,920	3,920
Trapezoid T Top	R50-TTOP-TZ-1712841-US3-R	1	1,631	1,631	1,631	1,631
Rectangle return T Top	R50-RTOP-TT-124241-US2-L	1	754	754	754	754
T Top 3000 edge	R50-TTOP-1EDGE-3000-BOW	2			509	1,018
T Top Chrome inlay	R50-TTOP-INLAY1-CHROME-BOW	2			137	274
3mm wood edge	Standard 3mm wood edge	3			100	300
Add BBF ped to each desk	R50-PED-BBF-ADD	2	444	888	444	888
Jan 2007 list price total			7,193		8,785	

RECEPTION 50 CONFIGURATIONS

R50-104 Standard desk top depth

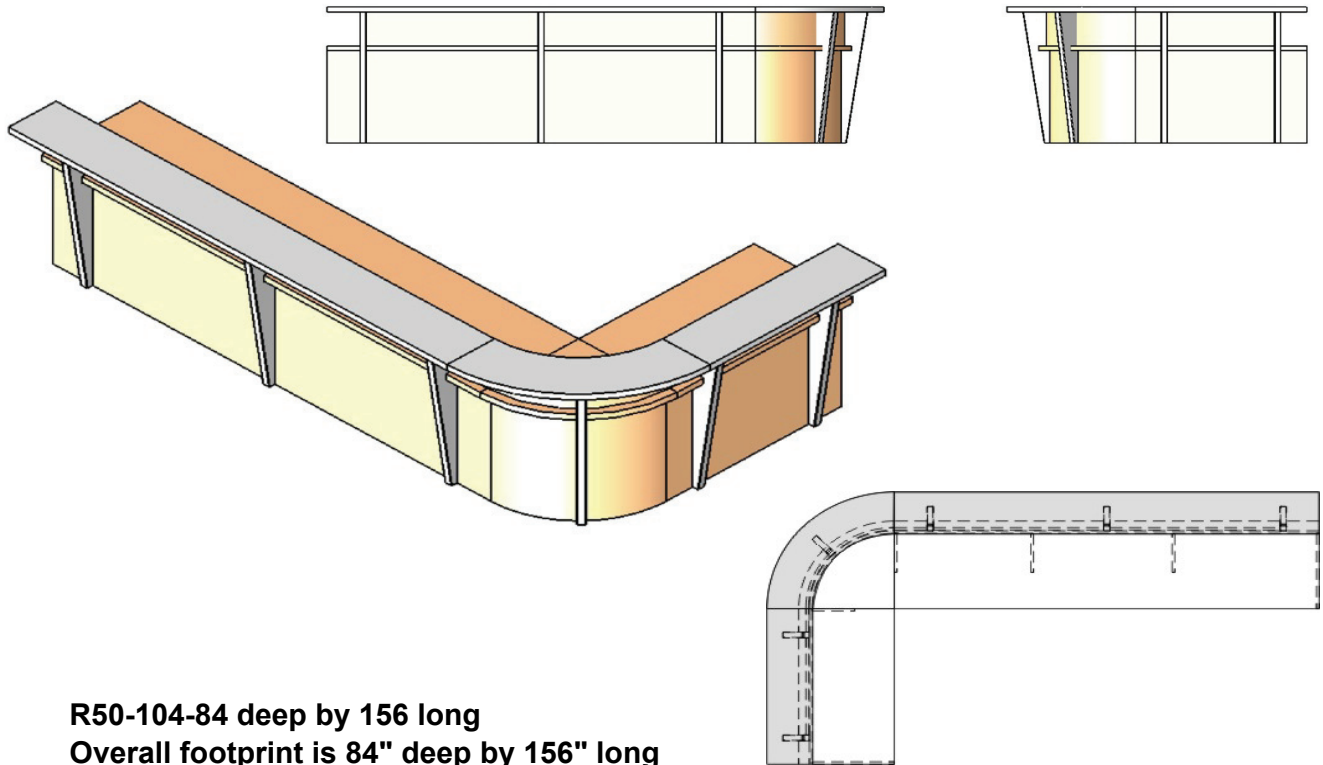

R50-104-84 deep by 156 long
Overall footprint is 84" deep by 156" long
Desk Top size is 24" deep by 120" long
Corner top is 24" deep
Desk Top size is 24" deep by 48" long
Transaction top is 13" deep, corner is 36" radius

Description	Model	Qty	WPE edge		Heavy Wood edge with inlay	
			List	Ext	List	Ext
Front desk 120" long	R50-D-TT-2412029	1	2,905	2,905	2,905	2,905
Corner top	R50-TOP-CNR-2424	1	755	755	755	755
Corner vertical	R50-VERT-CRNR-24-WP	1	969	969	969	969
Side desk 48" long	R50-D-TT-244829	1	1,595	1,595	1,595	1,595
Front transaction top	R50-TTOP-TT-1312041-US3	1	1,400	1,400	1,400	1,400
Corner transaction top	R50-CTOP-CRNR-24-WP	1	986	986	986	986
Return transaction top	R50-TTOP-TT-134841-US2	1	754	754	754	754
Front and return 3000 edge	R50-TTOP-1EDGE-3000-TT	2			509	1,018
Corner 3000 edge	R50-TTOP-1EDGE-3000-BOW	1			509	509
Front and return inlay	R50-TTOP-INLAY1-CHROME-TT	2			137	274
Corner inlay	R50-TTOP-INLAY1-CHROME-BOW	1			137	137
Standard 3mm wood edge	Standard 3mm wood edge	6			100	600
Add BBF pedestal	R50-PED-BBF-ADD	1	444	444	444	444
Add LF cabinet	R50-CAB-LF-ADD	1	800	800	800	800
Filler between top and t-top	R50-FILLER-WP	4	184	736	184	736
Filler for curved section	R50-FILLER-CC-24-WP	1	368	368	368	368
Jan 2007 list price total			11,712		14,250	

RECEPTION 50 CONFIGURATIONS

R50-105 Standard desk top depth

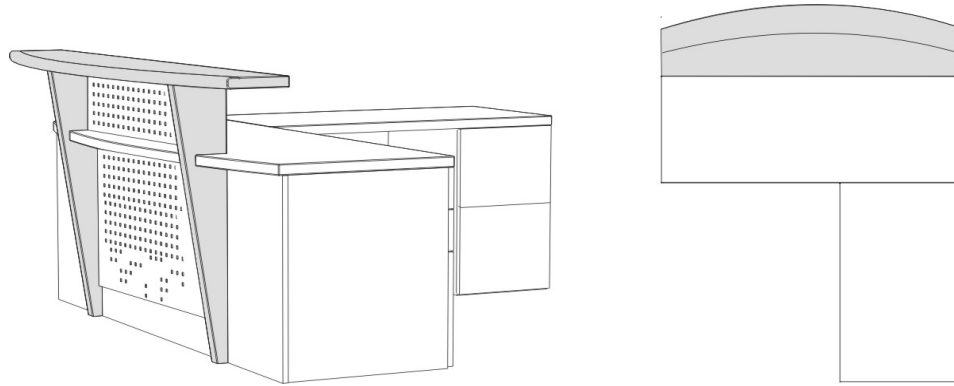

R50-105-60

Overall footprint is 77" deep by 72" long

Desk top is 24" deep by 72" long, Return top is 24" deep by 42" long

<i>Description</i>	<i>Model</i>	<i>Qty</i>	<i>List</i>	<i>Ext</i>	<i>List</i>	<i>Ext</i>
Desk rectangle	R50-D-BO-277229	1	2,297	2,297	2,297	2,297
Transaction top rectangle	R50-TTOP-BO-157241-US2	1	1,263	1,263	1,263	1,263
Series 50 return	S50-R-2442-FF-R	1	1,073	1,073	1,073	1,073
Return modesty panel	S50-MP-4229-VERT	1	168	168	168	168
Transaction top edge	R50-TTOP-1EDGE-3000-BOW	1			509	509
Transaction top inlay	R50-TTOP-INLAY1-CHROME-BOW	1			137	137
3mm wood edge	Standard 3mm wood edge	3			100	300
Add BBF ped to desk	R50-PED-BBF-ADD	1	444	444	444	444
WoodPlus filler	R50-FILLER-WP	1	184	184		
Metal filler	R50-FILLER-METAL	1			444	444
WoodPlus accent	R50-ACCENT-WP	1	184	184		
Metal accent	R50-ACCENT-METAL	1			560	560
Jan 2007 list price total			5,613		7,195	

Plan view dimensions - Standard desk top depth

Rectangle Desk with Rectangle Transaction top TTOP

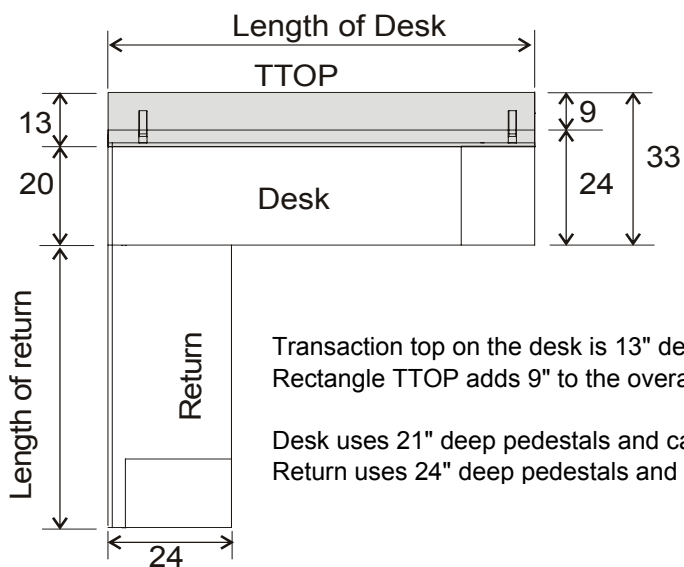

Transaction top on the desk is 13" deep and overhangs 9" in front of the desk
Rectangle TTOP adds 9" to the overall depth of desk

Desk uses 21" deep pedestals and cabinets.
Return uses 24" deep pedestals and cabinets.

Rectangle Desk with Rectangle Transaction top TTOP and Rectangle Return Transaction top RTOP

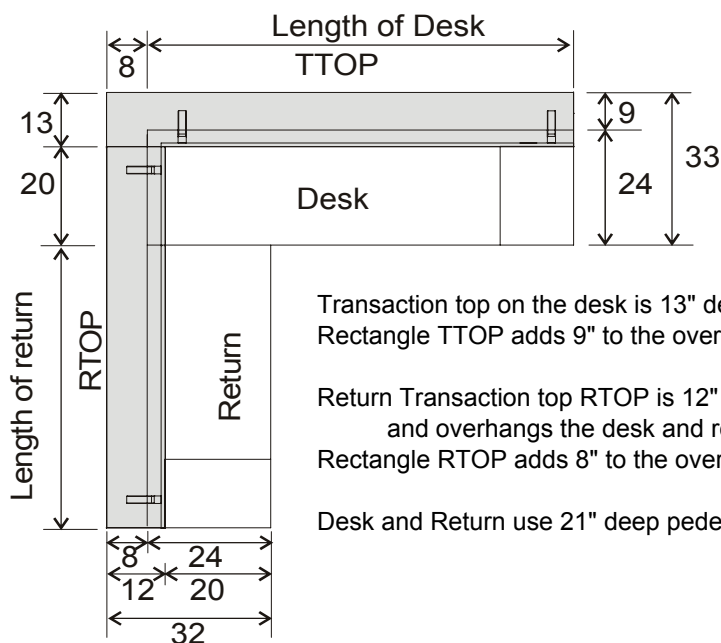

Transaction top on the desk is 13" deep and overhangs 9" in front of the desk
Rectangle TTOP adds 9" to the overall depth of desk

Return Transaction top RTOP is 12" deep
and overhangs the desk and return top by 8"
Rectangle RTOP adds 8" to the overall length of TTOP

Desk and Return use 21" deep pedestals and cabinets.

Plan view dimensions - Standard desk top depth

Rectangle Desk with Bow Front Transaction top TTOP

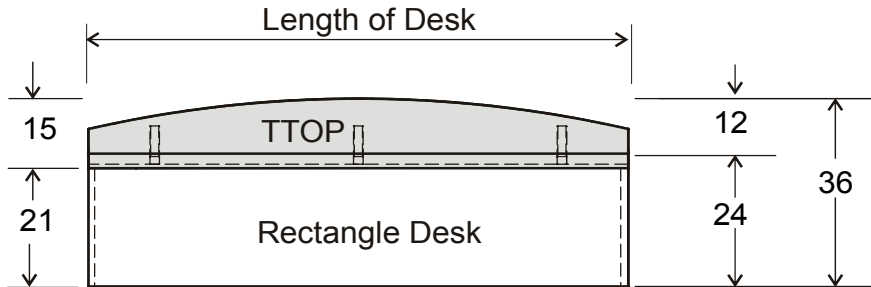

Desk uses 21" deep pedestals and cabinets.

Bow Front Desk with Bow Front Transaction top TTOP

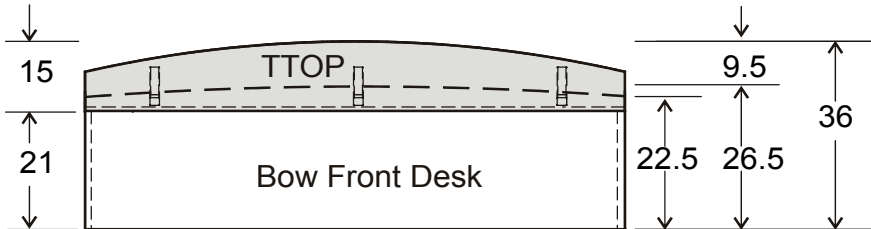

Desk uses 21" deep pedestals and cabinets.

Bow Front Transaction top on the desk is 15" deep

On a rectangular desk 24" deep, the Bow Front Transaction top adds 11" to the depth of the desk

On a bow front desk 30" deep, the Bow Front Transaction top adds 5" to the depth of the desk

Rectangle or Bow Front Desk with Bow Front Transaction top TTOP and Rectangle Return Transaction top RTOP

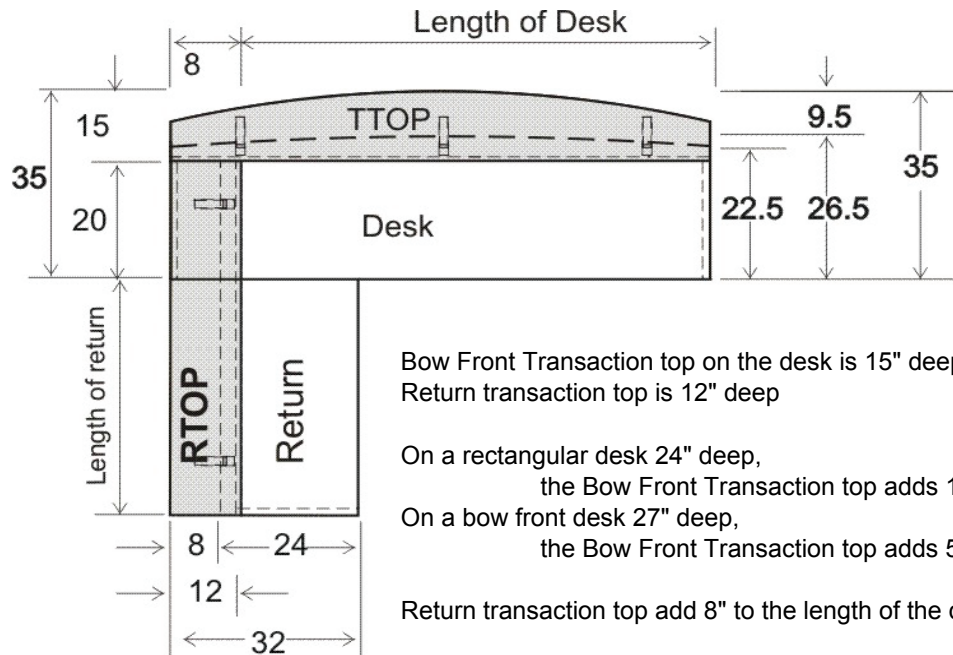

Desk and Return use 21" deep pedestals and cabinets.

Bow Front Transaction top on the desk is 15" deep

Return transaction top is 12" deep

On a rectangular desk 24" deep,

the Bow Front Transaction top adds 11" to the depth of the desk

On a bow front desk 27" deep,

the Bow Front Transaction top adds 5" to the depth of the desk

Return transaction top add 8" to the length of the desk TTOP

Plan view dimensions - Standard desk top depth

Rectangle with Trapezoid Transaction top TTOP - LEFT shown, RIGHT is opposite

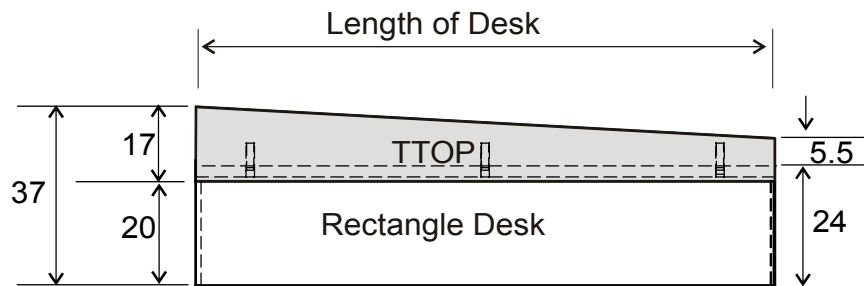

Desk uses 21" deep pedestals and cabinets.

Rectangle Desk with Trapezoid Transaction top TTOP
 Trapezoid TTOP is 17" deep and narrows to 9.5" deep.
 Trapezoid TTOP overhangs 5.5" to 13" on the customer side.

Trapezoid Desk with Trapezoid Transaction top TTOP - LEFT shown, RIGHT is opposite
 Rectangle Return Transaction top RTOP

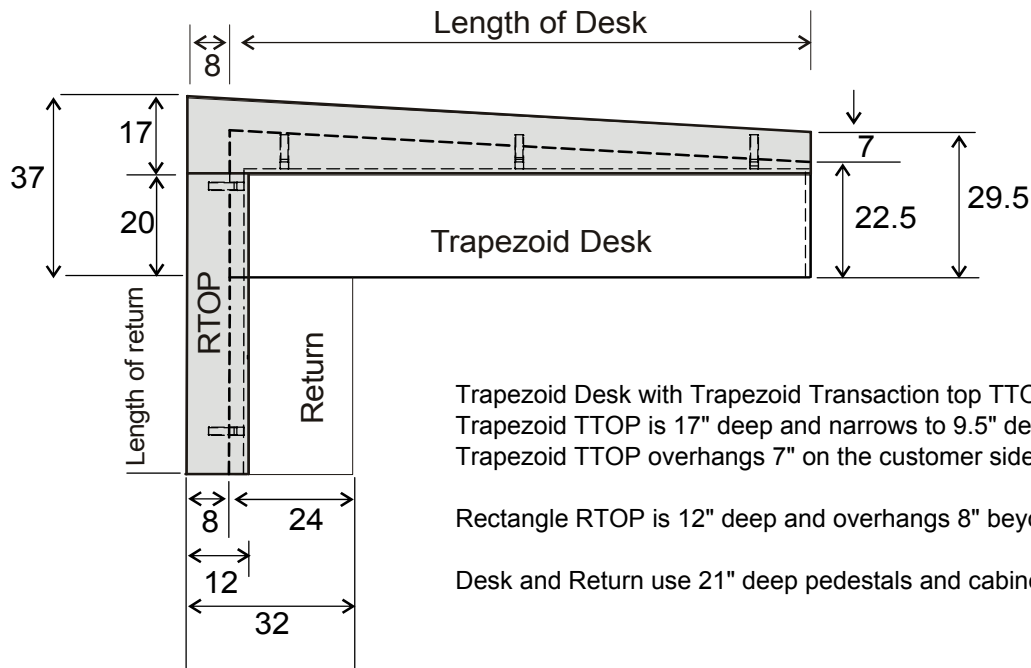

Trapezoid Desk with Trapezoid Transaction top TTOP
 Trapezoid TTOP is 17" deep and narrows to 9.5" deep.
 Trapezoid TTOP overhangs 7" on the customer side.

Rectangle RTOP is 12" deep and overhangs 8" beyond desk top.

Desk and Return use 21" deep pedestals and cabinets.

Ordering instructions

Desk Model		Qty	List Price
	A Desk top shape: TT Rectangle		\$
	A BO Bow		
	A TZ Trapezoid is Left or Right		
Desk is typically 24" deep. How long is the desk:			

Desk Support on Left End - choose one

R50-EP-2129-L	B typically the desk top is 24 deep, desk end is 21 deep	included
S50-PED-___-16___-LOCK	B for pedestal to replace end panel add \$444 each	\$
S50-CAB-___-___24-LOCK	B for LF or Combo cabinet to replace end panel, add \$800 each	\$

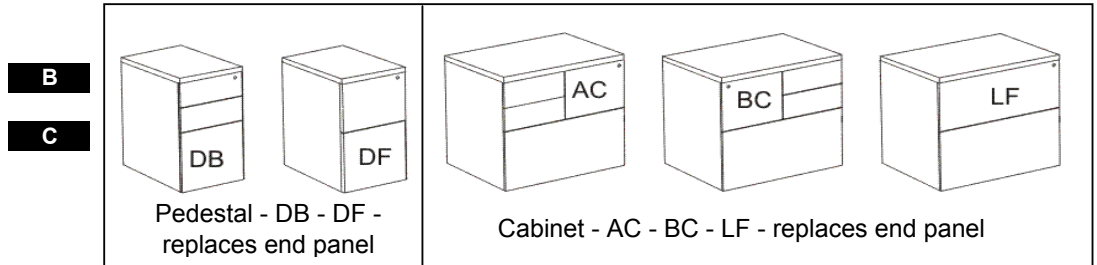

Desk Support on Right End - choose one

R50-EP-2129-R	C typically the desk top is 24 deep, desk end is 21 deep	included
S50-PED-___-16___-LOCK	C for pedestal to replace end panel add \$444 each	\$
S50-CAB-___-___24-LOCK	C for LF or Combo cabinet to replace end panel, add \$800 each	\$

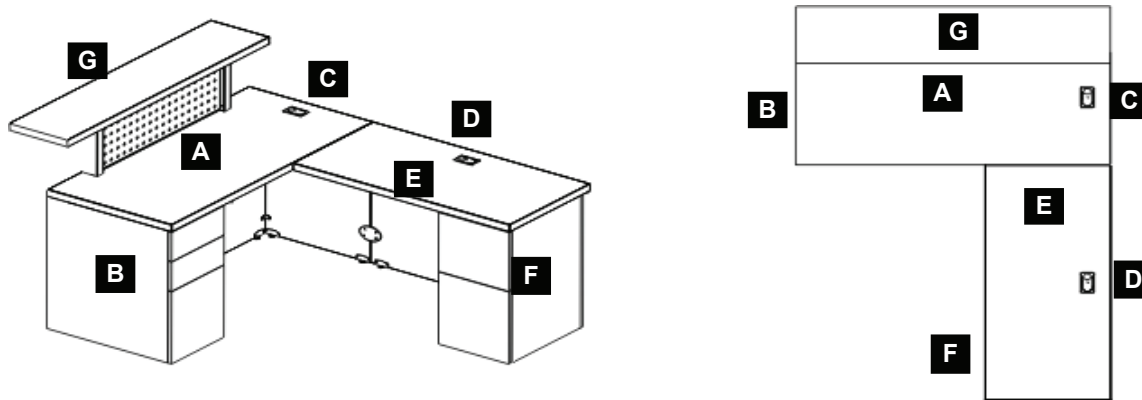

If 2 EP's are chosen	B-C you will need to order a Center Support: R50-EP-1229-GABLE	\$
----------------------	--	----

Note: both ends of each desk need to be secured with one of the following:
return, either Reception 50 or Series 50; Pedestal, Lateral File, or Cabinet;
or the end panel must be bracketed to the floor - bracket supplied by Magna Design

Desk Grommets:	D are located to the LEFT, CENTER or RIGHT when seated at station	\$
-----------------------	--	----

		List each
Left	OPTION-GRL	48
Center	OPTION-GRC	48
Right	OPTION-GRR	48

Ordering instructions

Desk TTOP transaction top

G	Transaction top shape:	TT	Rectangle	\$
G		BO	Bow	
G		TZ	Trapezoid is Left or Right	

Transaction top length is: _____

Are the vertical supports spaced 'Standard' or 'wide' S W

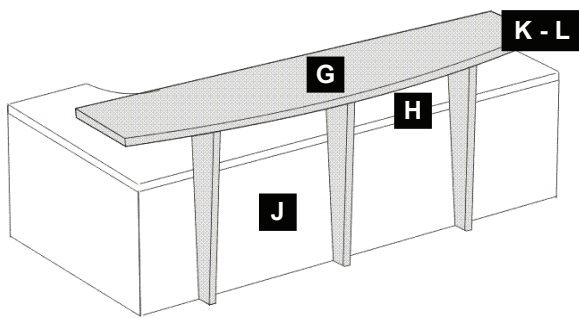

S or STANDARD spacing of the TTOP vertical supports allows the supports to be up to 18" in from the end of the desk

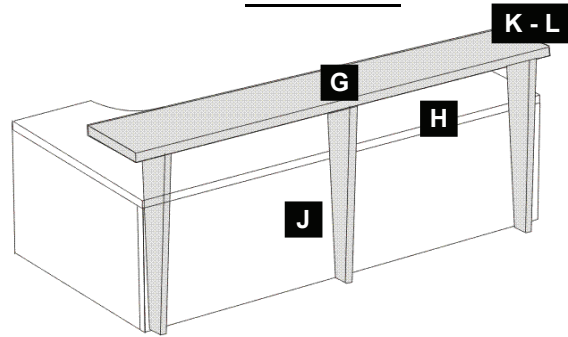

W or WIDE spacing of the TTOP vertical supports places the supports 3" in from the end of the desk

Filler panels between Transaction Top and the Desk Top

R50-FILLER-WP	H	Sized to fit between TTOP supports, TTOP and Desktop	each	\$
R50-FILLER-WP2	H	Sized to fit between TTOP supports, TTOP and Desktop	each	\$
R50-FILLER-METAL	H	Sized to fit between TTOP supports, TTOP and Desktop	each	\$

Accent panels below the Desk Top

R50-ACCENT-WP	J	Sized to fit between TTOP supports, below Desktop	each	\$
R50-ACCENT-WP2	J	Sized to fit between TTOP supports, below Desktop	each	\$
R50-ACCENT-METAL	J	Sized to fit between TTOP supports, below Desktop	each	\$

Transaction top EDGES

Transaction tops are 1.5" thick unless the edge profile chosen requires 1.75" thick top

Hardwood edge on customer side only

R50-TTOP-1EDGE-2000-	K	your choice from one of the '2000 Series' hardwood edges	each	\$
R50-TTOP-1EDGE-3000-	K	your choice from one of the '3000 Series' hardwood edges	each	\$

Hardwood edge on all exposed sides of transaction top

R50-TTOP-4EDGE-DET-	K	your choice from one of the 'Detailed' hardwood edges	per top	\$
R50-TTOP-4EDGE-ALUM-	K	your choice from one of the 'Aluminum' edges	per top	\$

Transaction top INLAYS

Inlay on customer side only

R50-TTOP-INLAY1-	L		each	\$
------------------	----------	--	------	----

Inlay on all exposed sides of transaction top

R50-TTOP-INLAY4-	L		per top	\$
------------------	----------	--	---------	----

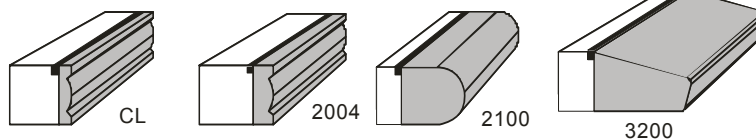

Ordering instructions

Desk Return **E** _____ \$

Return is which side of user: Left Right None

Please confirm Left / Right handedness by including a drawing with your order

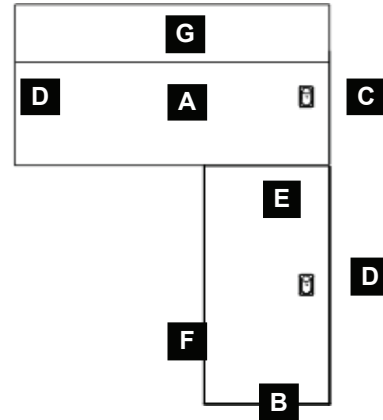
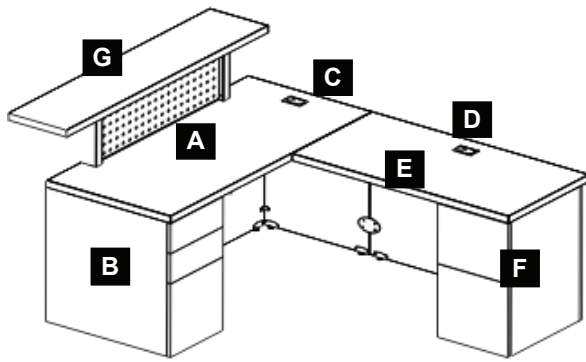

Return Support on End - choose one

R50-EP-2129-L or -R	F return top is 24 deep, return end is 24 deep	included
S50-PED-___-16___-LOCK	F for pedestal to replace end panel add \$444 each	\$
S50-CAB-___-___24-LOCK	F for LF or Combo cabinet to replace end panel, add \$800 each	\$

Note: Note: both ends of each desk need to be secured with one of the following:
return, either Reception 50 or Series 50; Pedestal, Lateral File, or Cabinet;
or the end panel must be bracketed to the floor - bracket supplied by Magna Design

Desk Grommets: **D** Left Right Center _____ \$

Return RTOP transaction top **R** All return transaction tops RTOP are rectangular _____ \$

Transaction top length is: _____
Are the vertical supports spaced 'standard' or 'wide' N W

How to calculate the length of the RTOP return transaction top
Add 20" to the length of the return

Same options and accessories as for TTOP:
Filler panels between Transaction Top

Accent panels below the Desk / Return Top
Transaction top EDGES
Transaction top INLAYS

Ordering instructions

Curved Corner unit

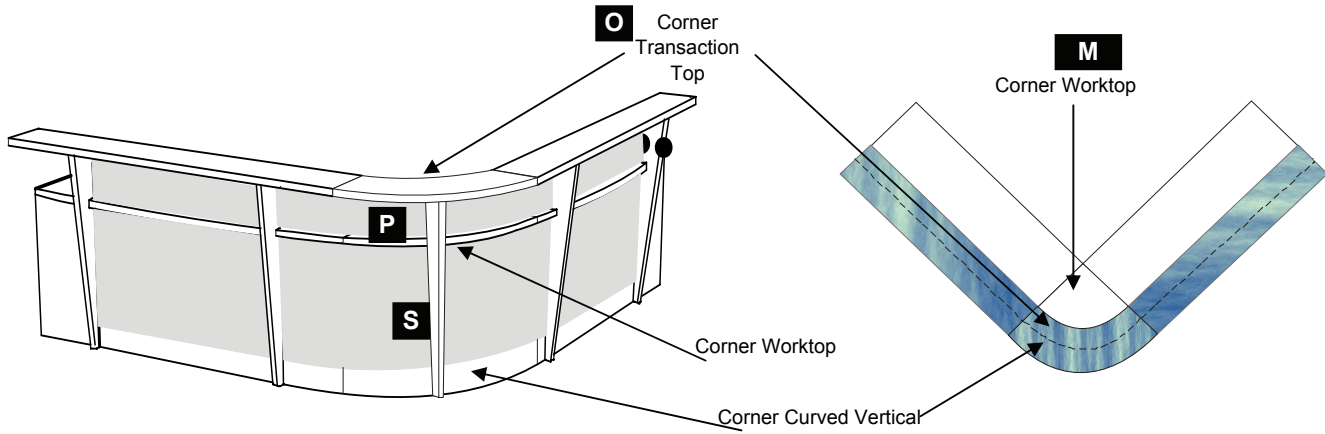

	N			
Curved Corner worktop	M	R50-TOP-CNR-2424	Standard depth	\$
		R50-TOP-CNR-2727	Deep corner top	\$
Curved Corner vertical	N	R50-VERT-CRNR-24-WP	Standard depth	\$
		R50-VERT-CRNR-24-METAL	Standard depth	\$
		R50-VERT-CRNR-27-WP	Deep corner top	\$
		R50-VERT-CRNR-27-METAL	Deep corner top	\$
Curved Corner CTOP	O	R50-CTOP-CRNR-24-WP	Standard depth	\$
		R50-CTOP-CRNR-27-WP	Deep corner top	\$
		requires a vertical panel below the worktop		
Curved Corner FILLER	P	R50-FILLER-CC-24-WP	Standard depth	\$
		R50-FILLER-CC-24-METAL	Standard depth	\$
		R50-FILLER-CC-27-WP	Deep corner top	\$
		R50-FILLER-CC-27-METAL	Deep corner top	\$
		Grain is vertical on WP WoodPlus Corner Curved Filler		
Curved Corner ACCENT	S	R50-ACCENT-CC-24-WP	Standard depth	\$
		R50-ACCENT-CC-24-METAL	Standard depth	\$
		R50-ACCENT-CC-27-WP	Deep corner top	\$
		R50-ACCENT-CC-27-METAL	Deep corner top	\$
		Grain is vertical on WP WoodPlus Corner Curved Accent		

Finishes and specifications

Transaction finish	Transaction edge type	Transaction edge finish	Transaction Inlay

Worktop finish	Worktop edge type	Worktop edge finish

Transaction top support finish

Lower drawer face finish	Lower case, vertical panel finish	Pull number

Filler panel finish	Accent panel finish

RECEPTION 50 DESKS - Standard depth desk tops

RECTANGLE

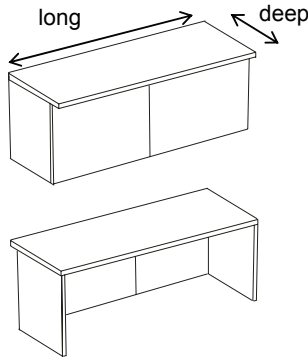

Model Number	List Price with two end panels		Footprint			Wgt
	WPE	STD	deep	long	high	
R50-D-TT-244829	1,595	1,701	24	48	29	
R50-D-TT-245429	1,731	1,837	24	54	29	
R50-D-TT-246029	1,731	1,837	24	60	29	
R50-D-TT-246629	1,958	2,064	24	66	29	
R50-D-TT-247229	1,958	2,064	24	72	29	
R50-D-TT-247829	2,238	2,344	24	78	29	
R50-D-TT-248429	2,238	2,344	24	84	29	
R50-D-TT-249029	2,354	2,460	24	90	29	
R50-D-TT-249629	2,539	2,645	24	96	29	
R50-D-TT-2410229	2,905	3,011	24	102	29	
R50-D-TT-2410829	2,905	3,011	24	108	29	
R50-D-TT-2411429	2,905	3,011	24	114	29	
R50-D-TT-2412029	2,905	3,011	24	120	29	

Use the 21" deep pedestals and cabinets with these desks

BOW FRONT

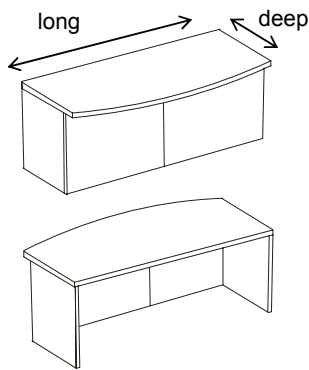

Model Number	List Price with two end panels		Footprint			Wgt
	WPE	STD	deep	long	high	
R50-D-BO-274829	1,994	2,100	26.5	48	29	
R50-D-BO-275429	2,091	2,197	26.5	54	29	
R50-D-BO-276029	2,091	2,197	26.5	60	29	
R50-D-BO-276629	2,290	2,396	26.5	66	29	
R50-D-BO-277229	2,297	2,403	26.5	72	29	
R50-D-BO-277829	2,671	2,777	26.5	78	29	
R50-D-BO-278429	2,671	2,777	26.5	84	29	
R50-D-BO-279029	2,790	2,896	26.5	90	29	
R50-D-BO-279629	2,975	3,081	26.5	96	29	
R50-D-BO-2710229	3,406	3,512	26.5	102	29	
R50-D-BO-2710829	3,406	3,512	26.5	108	29	
R50-D-BO-2711429	3,406	3,512	26.5	114	29	
R50-D-BO-2712029	3,406	3,512	26.5	120	29	

Use the 21" deep pedestals and cabinets with these desks

TRAPEZOID

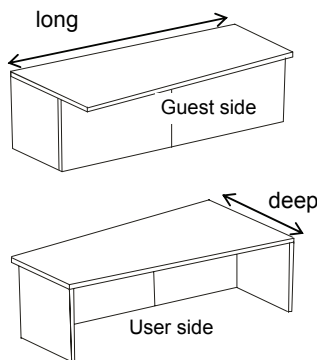

Model Number		List Price with two end panels		Footprint			Wgt
		WPE	STD	deep	long	high	
R50-D-TZ-304829	-L or -R	1,763	1,869	30	48	29	
R50-D-TZ-305429	-L or -R	1,860	1,966	30	54	29	
R50-D-TZ-306029	-L or -R	1,860	1,966	30	60	29	
R50-D-TZ-306629	-L or -R	2,059	2,165	30	66	29	
R50-D-TZ-307229	-L or -R	2,066	2,172	30	72	29	
R50-D-TZ-307829	-L or -R	2,440	2,546	30	78	29	
R50-D-TZ-308429	-L or -R	2,440	2,546	30	84	29	
R50-D-TZ-309029	-L or -R	2,559	2,665	30	90	29	
R50-D-TZ-309629	-L or -R	2,744	2,850	30	96	29	
R50-D-TZ-3010229	-L or -R	3,175	3,281	30	102	29	
R50-D-TZ-3010829	-L or -R	3,175	3,281	30	108	29	
R50-D-TZ-3011429	-L or -R	3,175	3,281	30	114	29	
R50-D-TZ-3012029	-L or -R	3,175	3,281	30	120	29	

Right shown - Left opposite

Use the 21" deep pedestals and cabinets with these desks

ADDING DRAWERS

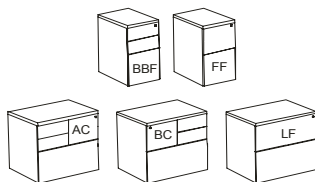

To replace one end panel with	WPE	STD	deep	long	high	Wgt
BBF pedestal add	444	444	21	16	29	
FF pedestal add	444	444	21	16	29	
Combo-A cabinet add	800	800	21	32	29	
Combo-B cabinet add	800	800	21	32	29	
Lateral File 30" long add	800	800	21	30	29	
Lateral File 36" long add	800	800	21	36	29	

Note: To ensure stability both ends of Reception 50 Desks must include a pedestal or cabinet, be attached to return or bridge, or be bracketed to floor.

RECTANGLE with Inside Radius - Standard depth desk tops

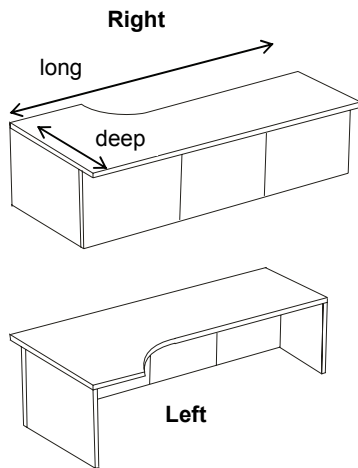

Model Number		List Price with two end panels		Footprint			Wgt
		WPE	STD	deep	long	high	
R50-D-TT-427229-IR	-L or -R	2,656	2,762	42	72	29	
R50-D-TT-427829-IR	-L or -R	3,039	3,145	42	78	29	
R50-D-TT-428429-IR	-L or -R	3,039	3,145	42	84	29	
R50-D-TT-429029-IR	-L or -R	3,168	3,274	42	90	29	
R50-D-TT-429629-IR	-L or -R	3,353	3,459	42	96	29	
R50-D-TT-4210229-IR	-L or -R	3,804	3,910	42	102	29	
R50-D-TT-4210829-IR	-L or -R	3,804	3,910	42	108	29	
R50-D-TT-4211429-IR	-L or -R	3,804	3,910	42	114	29	
R50-D-TT-4212029-IR	-L or -R	3,804	3,910	42	120	29	

Use the 21" deep pedestals and cabinets with these desks

BOW FRONT with Inside Radius

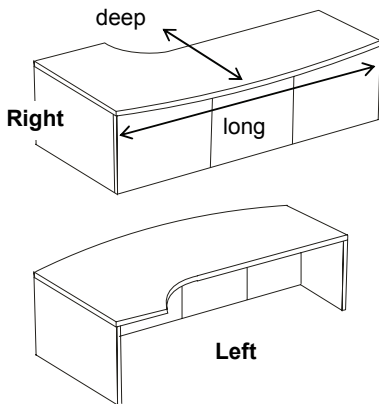

Model Number		List Price with two end panels		Footprint			Wgt
		WPE	STD	deep	long	high	
R50-D-BO-457229-IR	-L or -R	2,926	3,032	44.5	72	29	
R50-D-BO-457829-IR	-L or -R	3,300	3,406	44.5	78	29	
R50-D-BO-458429-IR	-L or -R	3,300	3,406	44.5	84	29	
R50-D-BO-459029-IR	-L or -R	3,419	3,525	44.5	90	29	
R50-D-BO-459629-IR	-L or -R	3,604	3,710	44.5	96	29	
R50-D-BO-4510229-IR	-L or -R	4,035	4,141	44.5	102	29	
R50-D-BO-4510829-IR	-L or -R	4,035	4,141	44.5	108	29	
R50-D-BO-4511429-IR	-L or -R	4,035	4,141	44.5	114	29	
R50-D-BO-4512029-IR	-L or -R	4,035	4,141	44.5	120	29	

Use the 21" deep pedestals and cabinets with these desks

TRAPEZOID with Inside Radius

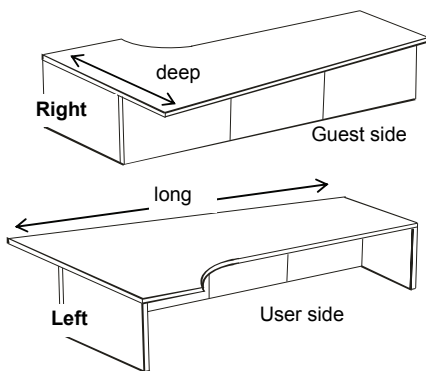

Model Number		List Price with two end panels		Footprint			Wgt
		WPE	STD	deep	long	high	
R50-D-TZ-487229-IR	-L or -R	2,811	2,917	48	72	29	
R50-D-TZ-487829-IR	-L or -R	3,185	3,291	48	78	29	
R50-D-TZ-488429-IR	-L or -R	3,185	3,291	48	84	29	
R50-D-TZ-489029-IR	-L or -R	3,304	3,410	48	90	29	
R50-D-TZ-489629-IR	-L or -R	3,489	3,595	48	96	29	
R50-D-TZ-4810229-IR	-L or -R	3,920	4,026	48	102	29	
R50-D-TZ-4810829-IR	-L or -R	3,920	4,026	48	108	29	
R50-D-TZ-4811429-IR	-L or -R	3,920	4,026	48	114	29	
R50-D-TZ-4812029-IR	-L or -R	3,920	4,026	48	120	29	

Use the 21" deep pedestals and cabinets with these desks

Note: To ensure stability both ends of Reception 50 Desks must include a pedestal or cabinet, be attached to return or bridge, or be bracketed to floor.

RECTANGLE with Double Inside Radius - Standard depth desk tops

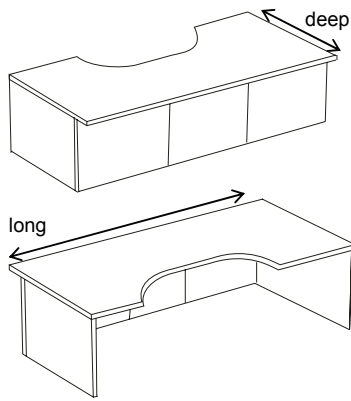

Model Number	List Price with two end panels		Footprint			Wgt
	WPE	STD	deep	long	high	
R50-D-TT-428429-DIR	3,490	3,596	42	84	29	
R50-D-TT-429029-DIR	3,619	3,725	42	90	29	
R50-D-TT-429629-DIR	3,804	3,910	42	96	29	
R50-D-TT-4210229-DIR	4,255	4,361	42	102	29	
R50-D-TT-4210829-DIR	4,255	4,361	42	108	29	
R50-D-TT-4211429-DIR	4,255	4,361	42	114	29	
R50-D-TT-4212029-DIR	4,255	4,361	42	120	29	

Use the 21" deep pedestals and cabinets with these desks

BOW FRONT with Double Inside Radius

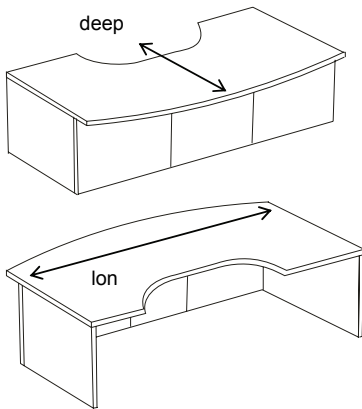

Model Number	List Price with two end panels		Footprint			Wgt
	WPE	STD	deep	long	high	
R50-D-BO-458429-DIR	3,868	3,974	44.5	84	29	
R50-D-BO-459029-DIR	3,997	4,103	44.5	90	29	
R50-D-BO-459629-DIR	4,182	4,288	44.5	96	29	
R50-D-BO-4510229-DIR	4,633	4,739	44.5	102	29	
R50-D-BO-4510829-DIR	4,633	4,739	44.5	108	29	
R50-D-BO-4511429-DIR	4,633	4,739	44.5	114	29	
R50-D-BO-4512029-DIR	4,633	4,739	44.5	120	29	

Use the 21" deep pedestals and cabinets with these desks

TRAPEZOID with Double Inside Radius

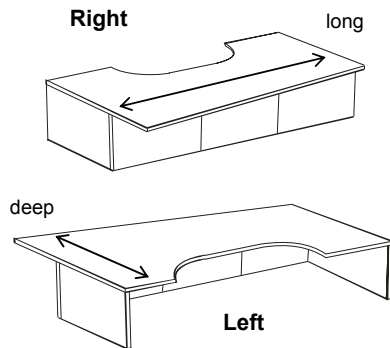

Model Number		List Price with two end panels		Footprint			Wgt
		WPE	STD	deep	long	high	
R50-D-TZ-488429-DIR	-L or -R	3,868	3,974	48	84	29	
R50-D-TZ-489029-DIR	-L or -R	3,997	4,103	48	90	29	
R50-D-TZ-489629-DIR	-L or -R	4,182	4,288	48	96	29	
R50-D-TZ-4810229-DIR	-L or -R	4,633	4,739	48	102	29	
R50-D-TZ-4810829-DIR	-L or -R	4,633	4,739	48	108	29	
R50-D-TZ-4811429-DIR	-L or -R	4,633	4,739	48	114	29	
R50-D-TZ-4812029-DIR	-L or -R	4,633	4,739	48	120	29	

Use the 21" deep pedestals and cabinets with these desks

Note: To ensure stability both ends of Reception 50 Desks must include a pedestal or cabinet, be attached to return or bridge, or be bracketed to floor.

CORNER TRANSACTION TOPS, WORKTOPS AND VERTICALS

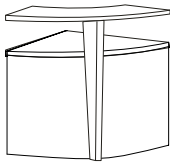
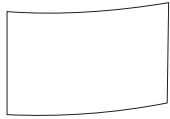
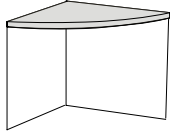
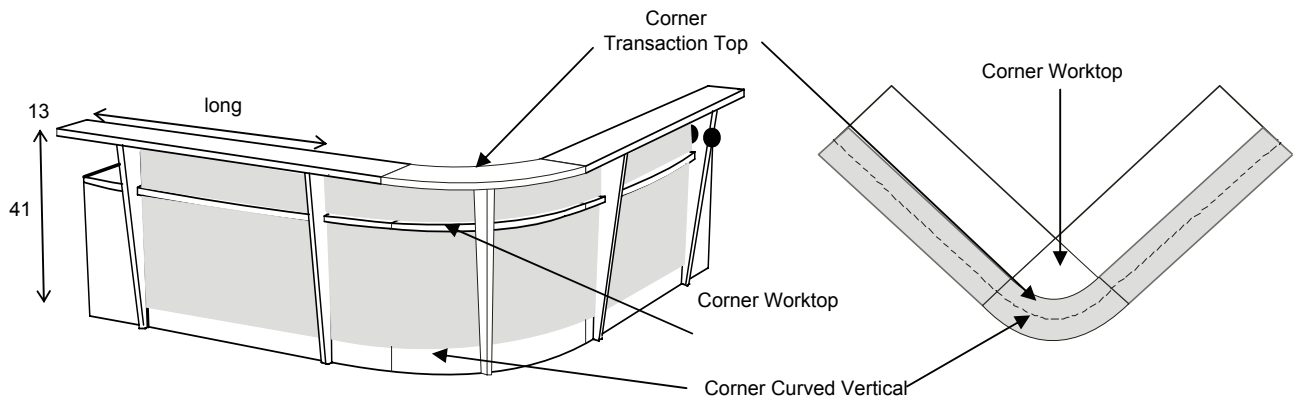

Model Number		WPE	STD	Footprint			Wgt
				deep	long	high	
R50-TOP-CNR-2424	standard top depth	755	861	24	24		
R50-TOP-CNR-2727	deep corner top	755	861	24	24		

Corner Top includes hardware to install

R50-VERT-CRNR-24-WP	standard top depth	969	969	24	24	29
R50-VERT-CRNR-24-METAL	standard top depth	1,179	1,179	24	24	29
R50-VERT-CRNR-27-WP	deep corner top	969	969	27	27	29
R50-VERT-CRNR-27-METAL	deep corner top	1,179	1,179	27	27	29

Grain is vertical on WP WoodPlus corner curved accent

Corner Curved Vertical is required when a Corner Transaction Top is ordered

R50-CTOP-CRNR-24-WP	standard top depth	986	1,092	36	36	41
R50-CTOP-CRNR-27-WP	deep corner top	986	1,092	39	39	41

For a proper fit, use a rectangular TT TTOP adjacent to this corner transaction top CTOP

Corner Curved Vertical is required when a Corner Transaction Top is ordered

Corner Transaction Top includes upright support

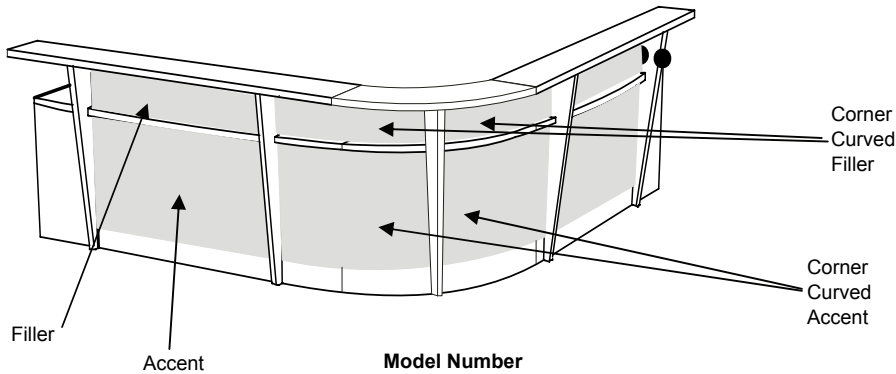

Model Number		WPE	STD
R50-FILLER-CC-24-WP	standard top depth	368	368
R50-FILLER-CC-24-METAL	standard top depth	622	622
R50-FILLER-CC-27-WP	deep corner top	368	368
R50-FILLER-CC-27-METAL	deep corner top	622	622

Grain is vertical on WP WoodPlus and WP2 WoodPlus2 Corner Curved Filler

R50-ACCENT-CC-24-WP	standard top depth	368	368
R50-ACCENT-CC-24-METAL	standard top depth	784	784
R50-ACCENT-CC-27-WP	deep corner top	368	368
R50-ACCENT-CC-27-METAL	deep corner top	784	784

Grain is vertical on WP WoodPlus and WP2 WoodPlus2 Corner Curved Accent

RECEPTION 50 RETURNS to accommodate an RTOP return transaction top

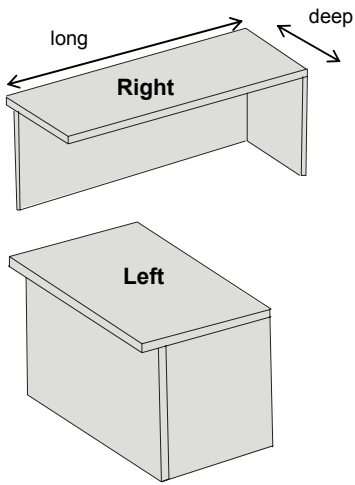

Designed to accommodate an RTOP return transaction top

Model Number	WPE	STD	Footprint			Wgt
			deep	long	high	
R50-R-TT-242429	-L or -R	1,118	1,224	24	24	29
R50-R-TT-243029	-L or -R	1,136	1,242	24	30	29
R50-R-TT-243629	-L or -R	1,160	1,266	24	36	29
R50-R-TT-244229	-L or -R	1,208	1,314	24	42	29
R50-R-TT-244829	-L or -R	1,154	1,260	24	48	29
R50-R-TT-245429	-L or -R	1,290	1,396	24	54	29
R50-R-TT-246029	-L or -R	1,290	1,396	24	60	29
R50-R-TT-246629	-L or -R	1,517	1,623	24	66	29
R50-R-TT-247229	-L or -R	1,517	1,623	24	72	29

Use the 21" deep pedestals and cabinets with these returns

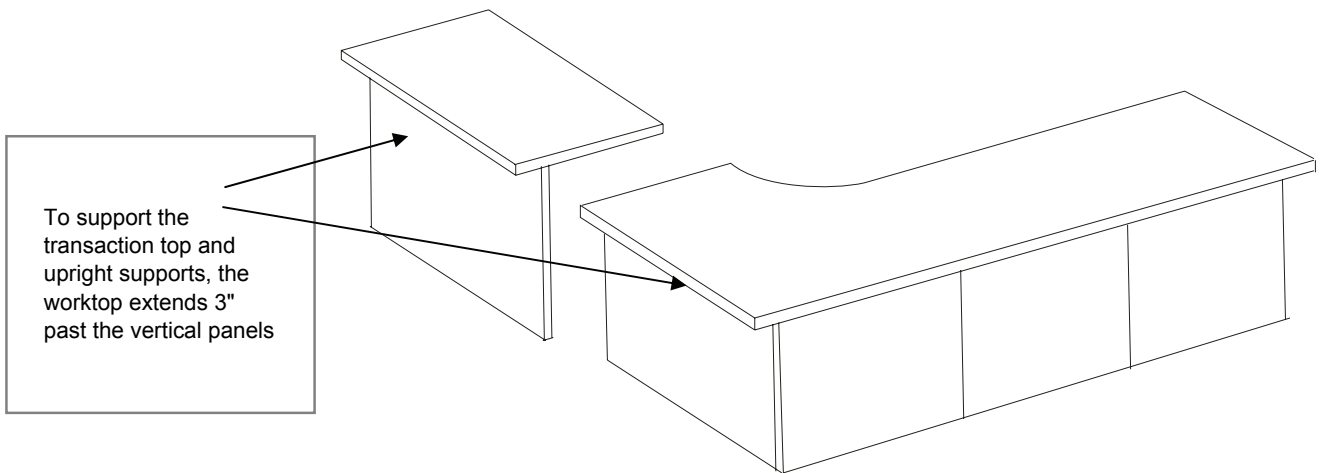
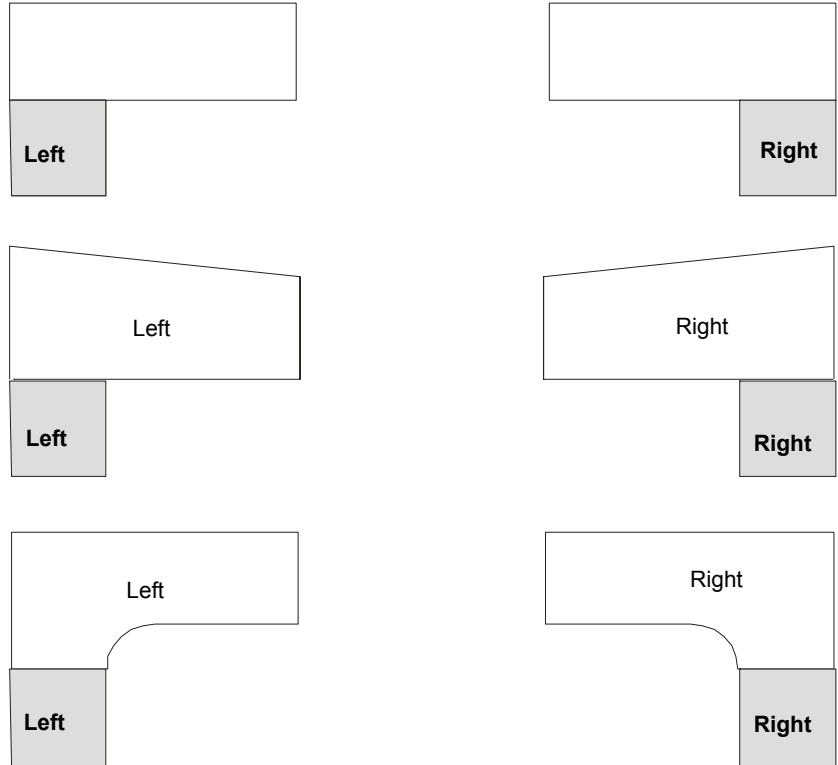

RECEPTION 50 BRIDGES to accommodate an RTOP return transaction top

Designed to accommodate an RTOP return transaction top

Model Number		WPE	STD	Footprint			Wgt
				deep	long	high	
R50-B-TT-242429	-L or -R	1,118	1,224	24	24	29	
R50-B-TT-243029	-L or -R	1,136	1,242	24	30	29	
R50-B-TT-243629	-L or -R	1,160	1,266	24	36	29	
R50-B-TT-244229	-L or -R	1,208	1,314	24	42	29	
R50-B-TT-244829	-L or -R	1,154	1,260	24	48	29	
R50-B-TT-245429	-L or -R	1,290	1,396	24	54	29	
R50-B-TT-246029	-L or -R	1,290	1,396	24	60	29	

RECEPTION 50 CREDENZAS to accommodate an RTOP return transaction top

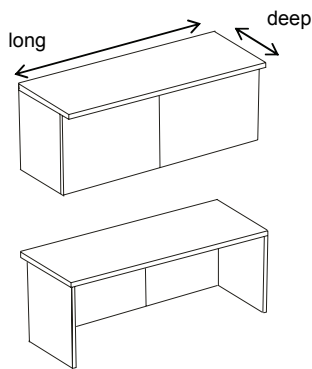

Model Number	List Price with two end panels		Footprint			Wgt
	WPE	STD	deep	long	high	
R50-C-TT-244829	1,595	1,701	24	48	29	
R50-C-TT-245429	1,731	1,837	24	54	29	
R50-C-TT-246029	1,731	1,837	24	60	29	
R50-C-TT-246629	1,958	2,064	24	66	29	
R50-C-TT-247229	1,958	2,064	24	72	29	
R50-C-TT-247829	2,238	2,344	24	78	29	
R50-C-TT-248429	2,238	2,344	24	84	29	
R50-C-TT-249029	2,354	2,460	24	90	29	
R50-C-TT-249629	2,539	2,645	24	96	29	
R50-C-TT-2410229	2,905	3,011	24	102	29	
R50-C-TT-2410829	2,905	3,011	24	108	29	
R50-C-TT-2411429	2,905	3,011	24	114	29	
R50-C-TT-2412029	2,905	3,011	24	120	29	

Use the 21" deep pedestals and cabinets with these desks

Transaction tops with Uprights at US standard or UW wide spacing

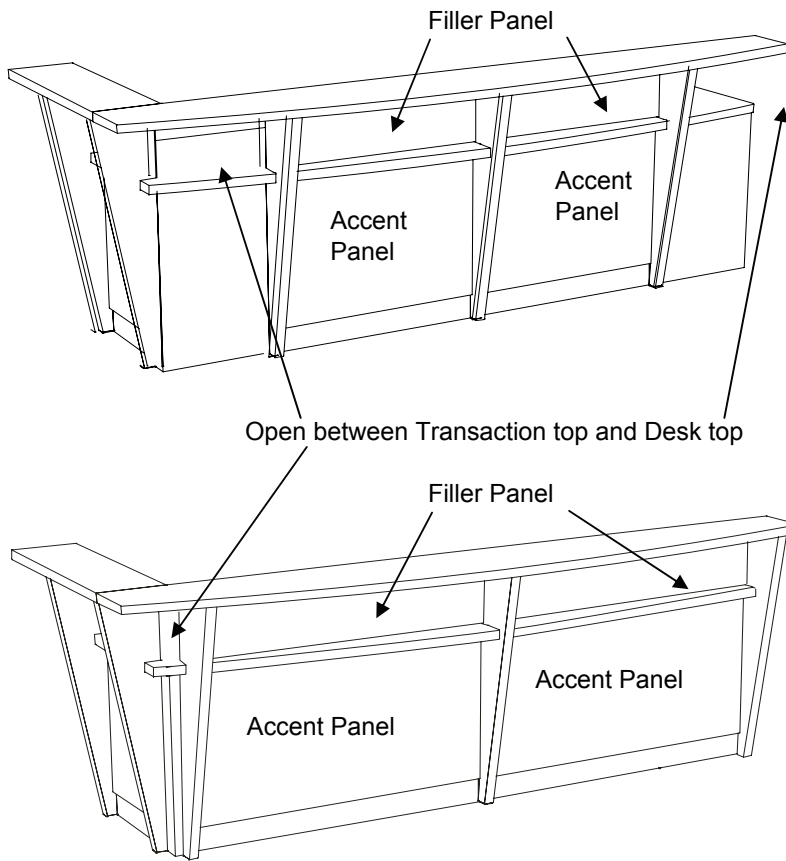

Bow front transaction top shown with US standard upright spacing

Bow front transaction top shown with UW wide upright spacing

FILLERS

	WPE	STD	
R50-FILLER-WP	184	184	fits between one pair of uprights
R50-FILLER-WP2	220	220	fits between one pair of uprights
R50-FILLER-METAL	444	444	fits between one pair of uprights

ACCENTS

R50-ACCENT-WP	184	184	fits between one pair of uprights
R50-ACCENT-WP2	440	440	fits between one pair of uprights
R50-ACCENT-METAL	560	560	fits between one pair of uprights
R50-ACCENT-METAL-LOGO	1,394	1,394	fits between one pair of uprights

R50-ACCENT-METAL-LOGO is a metal accent panel with your company logo cut into it

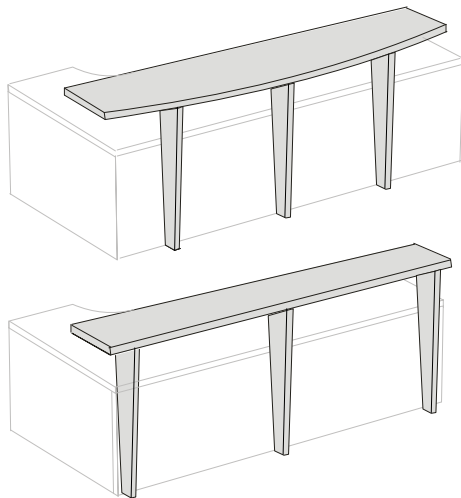

Bow front transaction top shown with US standard upright spacing

Rectangular transaction top shown with UW wide upright spacing

TRANSACTION TOPS RECTANGULAR

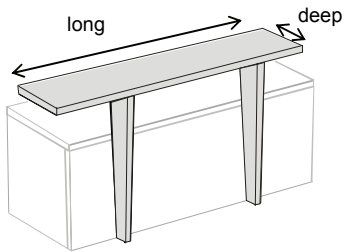

UPRIGHT SUPPORTS AT 'STANDARD' SPACING

Add a front Transaction Top to the RECTANGLE desk
with Standard vertical spacing

	WPE	STD	TTOP size			
			verts	deep	long	high
R50-TTOP-TT-134841-US2	754	860	2	13	48	41
R50-TTOP-TT-135441-US2	878	984	2	13	54	41
R50-TTOP-TT-136041-US2	878	984	2	13	60	41
R50-TTOP-TT-136641-US2	916	1,022	2	13	66	41
R50-TTOP-TT-137241-US2	916	1,022	2	13	72	41
R50-TTOP-TT-137841-US2	921	1,027	2	13	78	41
R50-TTOP-TT-138441-US2	921	1,027	2	13	84	41
R50-TTOP-TT-139041-US3	1,257	1,363	3	13	90	41
R50-TTOP-TT-139641-US3	1,257	1,363	3	13	96	41
R50-TTOP-TT-1310241-US3	1,400	1,506	3	13	102	41
R50-TTOP-TT-1310841-US3	1,400	1,506	3	13	108	41
R50-TTOP-TT-1311441-US3	1,400	1,506	3	13	114	41
R50-TTOP-TT-1312041-US3	1,400	1,506	3	13	120	41

TRANSACTION TOPS BOW FRONT

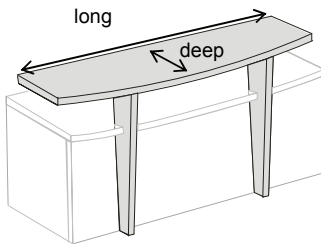

Add a BOW front Transaction Top to the BOW FRONT or RECTANGLE desk
with Standard vertical spacing

	WPE	STD	verts	deep	long	high
R50-TTOP-BO-154841-US2	1,100	1,206	2	15	48	41
R50-TTOP-BO-155441-US2	1,224	1,330	2	15	54	41
R50-TTOP-BO-156041-US2	1,224	1,330	2	15	60	41
R50-TTOP-BO-156641-US2	1,263	1,369	2	15	66	41
R50-TTOP-BO-157241-US2	1,263	1,369	2	15	72	41
R50-TTOP-BO-157841-US2	1,267	1,373	2	15	78	41
R50-TTOP-BO-158441-US2	1,267	1,373	2	15	84	41
R50-TTOP-BO-159041-US3	1,604	1,710	3	15	90	41
R50-TTOP-BO-159641-US3	1,604	1,710	3	15	96	41
R50-TTOP-BO-1510241-US3	1,747	1,853	3	15	102	41
R50-TTOP-BO-1510841-US3	1,747	1,853	3	15	108	41
R50-TTOP-BO-1511541-US3	1,747	1,853	3	15	114	41
R50-TTOP-BO-1512041-US3	1,747	1,853	3	15	120	41

TRANSACTION TOPS TRAPEZOID

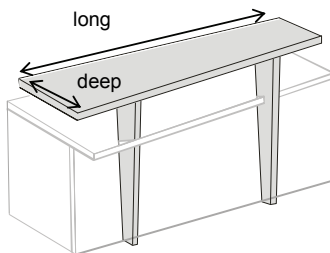

Add a TRAPEZOID front Transaction Top to the TRAPEZOID or RECTANGLE desk
with Standard vertical spacing

	WPE	STD	verts	deep	long	high
R50-TTOP-TZ-174841-US2	-L or -R	985	2	17	48	41
R50-TTOP-TZ-175441-US2	-L or -R	1,109	2	17	54	41
R50-TTOP-TZ-176041-US2	-L or -R	1,109	2	17	60	41
R50-TTOP-TZ-176641-US2	-L or -R	1,147	2	17	66	41
R50-TTOP-TZ-177241-US2	-L or -R	1,147	2	17	72	41
R50-TTOP-TZ-177841-US2	-L or -R	1,152	2	17	78	41
R50-TTOP-TZ-178441-US2	-L or -R	1,152	2	17	84	41
R50-TTOP-TZ-179041-US3	-L or -R	1,488	3	17	90	41
R50-TTOP-TZ-179641-US3	-L or -R	1,488	3	17	96	41
R50-TTOP-TZ-1710241-US3	-L or -R	1,631	3	17	102	41
R50-TTOP-TZ-1710841-US3	-L or -R	1,631	3	17	108	41
R50-TTOP-TZ-1711441-US3	-L or -R	1,631	3	17	114	41
R50-TTOP-TZ-1712041-US3	-L or -R	1,631	3	17	120	41

FILLERS AND ACCENTS

	WPE	STD	
R50-FILLER-WP	184	184	fits between one pair of uprights
R50-FILLER-WP2	220	220	fits between one pair of uprights
R50-FILLER-METAL	444	444	fits between one pair of uprights

R50-ACCENT-WP	184	184	fits between one pair of uprights
R50-ACCENT-WP2	440	440	fits between one pair of uprights
R50-ACCENT-METAL	560	560	fits between one pair of uprights

UPRIGHT SUPPORTS AT 'WIDE' SPACING

TRANSACTION TOPS RECTANGULAR

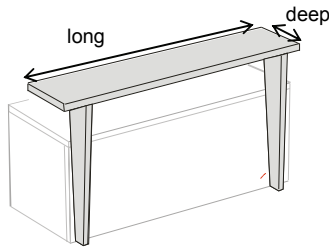

Add a front Transaction Top to the RECTANGLE desk with WIDE vertical spacing

	WPE	STD	TTOP size			
			verts	deep	long	high
R50-TTOP-TT-134841-UW2	754	860	2	13	48	41
R50-TTOP-TT-135441-UW2	878	984	2	13	54	41
R50-TTOP-TT-136041-UW2	878	984	2	13	60	41
R50-TTOP-TT-136641-UW2	916	1,022	2	13	66	41
R50-TTOP-TT-137241-UW2	916	1,022	2	13	72	41
R50-TTOP-TT-137841-UW2	921	1,027	2	13	78	41
R50-TTOP-TT-138441-UW2	921	1,027	2	13	84	41
R50-TTOP-TT-139041-UW3	1,026	1,132	3	13	90	41
R50-TTOP-TT-139641-UW3	1,026	1,132	3	13	96	41
R50-TTOP-TT-1310241-UW4	1,631	1,737	4	13	102	41
R50-TTOP-TT-1310841-UW4	1,631	1,737	4	13	108	41
R50-TTOP-TT-1311441-UW4	1,631	1,737	4	13	114	41
R50-TTOP-TT-1312041-UW4	1,631	1,737	4	13	120	41

TRANSACTION TOPS BOW FRONT

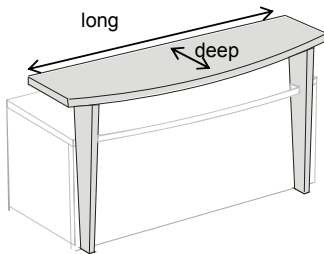

Add a BOW front Transaction Top to the BOW FRONT or RECTANGLE desk with WIDE vertical spacing

	WPE	STD	verts	deep	long	high
R50-TTOP-BO-154841-UW2	1,100	1,206	2	15	48	41
R50-TTOP-BO-155441-UW2	1,455	1,561	2	15	54	41
R50-TTOP-BO-156041-UW2	1,455	1,561	2	15	60	41
R50-TTOP-BO-156641-UW2	1,494	1,600	2	15	66	41
R50-TTOP-BO-157241-UW2	1,494	1,600	2	15	72	41
R50-TTOP-BO-157841-UW2	1,498	1,604	2	15	78	41
R50-TTOP-BO-158441-UW2	1,498	1,604	2	15	84	41
R50-TTOP-BO-159041-UW3	1,604	1,710	3	15	90	41
R50-TTOP-BO-159641-UW3	1,604	1,710	3	15	96	41
R50-TTOP-BO-1510241-UW4	1,978	2,084	4	15	102	41
R50-TTOP-BO-1510841-UW4	1,978	2,084	4	15	108	41
R50-TTOP-BO-1511541-UW4	1,978	2,084	4	15	114	41
R50-TTOP-BO-1512041-UW4	1,978	2,084	4	15	120	41

TRANSACTION TOPS TRAPEZOID

Add a TRAPEZOID front Transaction Top to the TRAPEZOID or RECTANGLE desk with WIDE vertical spacing

		WPE	STD	verts	deep	long	high
R50-TTOP-TZ-174841-UW2	-L or -R	985	1,091	2	17	48	41
R50-TTOP-TZ-175441-UW2	-L or -R	1,340	1,446	2	17	54	41
R50-TTOP-TZ-176041-UW2	-L or -R	1,340	1,446	2	17	60	41
R50-TTOP-TZ-176641-UW2	-L or -R	1,378	1,484	2	17	66	41
R50-TTOP-TZ-177241-UW2	-L or -R	1,378	1,484	2	17	72	41
R50-TTOP-TZ-177841-UW2	-L or -R	1,383	1,489	2	17	78	41
R50-TTOP-TZ-178441-UW2	-L or -R	1,383	1,489	2	17	84	41
R50-TTOP-TZ-179041-UW3	-L or -R	1,488	1,594	3	17	90	41
R50-TTOP-TZ-179641-UW3	-L or -R	1,488	1,594	3	17	96	41
R50-TTOP-TZ-1710241-UW4	-L or -R	1,862	1,968	4	17	102	41
R50-TTOP-TZ-1710841-UW4	-L or -R	1,862	1,968	4	17	108	41
R50-TTOP-TZ-1711441-UW4	-L or -R	1,862	1,968	4	17	114	41
R50-TTOP-TZ-1712041-UW4	-L or -R	1,862	1,968	4	17	120	41

FILLERS AND ACCENTS

	WPE	STD	
R50-FILLER-WP	184	184	fits between one pair of uprights
R50-FILLER-WP2	220	220	fits between one pair of uprights
R50-FILLER-METAL	444	444	fits between one pair of uprights

R50-ACCENT-WP	184	184	fits between one pair of uprights
R50-ACCENT-WP2	440	440	fits between one pair of uprights
R50-ACCENT-METAL	560	560	fits between one pair of uprights

RETURN RTOP TRANSACTION TOPS

VERTICAL SUPPORTS AT 'STANDARD' SPACING

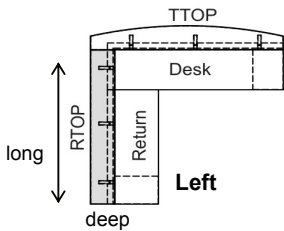
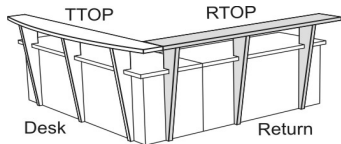
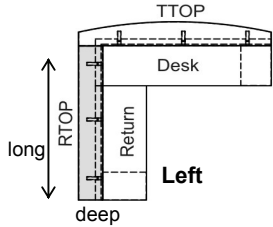
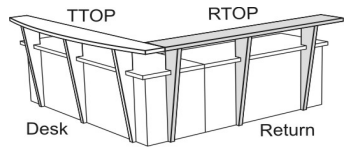

Add a RTOP RETURN Transaction Top to the R50 return with Standard vertical spacing

		WPE	STD	RTOP size			
				verts	deep	long	high
R50-RTOP-TT-122041-S-FB	-L or -R	681	787	1	12	20	41
R50-RTOP-TT-122341-S-FB	-L or -R	681	787	1	12	23	41
R50-RTOP-TT-124441-S-FB	-L or -R	754	860	2	12	44	41
R50-RTOP-TT-124741-S-FB	-L or -R	754	860	2	12	47	41
R50-RTOP-TT-125041-S-FB	-L or -R	878	984	2	12	50	41
R50-RTOP-TT-125341-S-FB	-L or -R	878	984	2	12	53	41
R50-RTOP-TT-125641-S-FB	-L or -R	878	984	2	12	56	41
R50-RTOP-TT-125941-S-FB	-L or -R	878	984	2	12	59	41

Grain runs from Front to Back on the 'FB' return transaction tops

Add a RTOP RETURN Transaction Top to the R50 return with Standard vertical spacing

		WPE	STD	RTOP size			
				verts	deep	long	high
R50-RTOP-TT-122041-US1	-L or -R	681	787	2	12	20	41
R50-RTOP-TT-122341-US1	-L or -R	681	787	2	12	23	41
R50-RTOP-TT-124441-US2-L	-L or -R	754	860	2	12	44	41
R50-RTOP-TT-124741-US2-L	-L or -R	754	860	2	12	47	41
R50-RTOP-TT-125041-US2-L	-L or -R	878	984	2	12	50	41
R50-RTOP-TT-125341-US2-L	-L or -R	878	984	2	12	53	41
R50-RTOP-TT-125641-US2-L	-L or -R	878	984	2	12	56	41
R50-RTOP-TT-125941-US2-L	-L or -R	878	984	2	12	59	41
R50-RTOP-TT-126241-US2-L	-L or -R	916	1,022	2	12	62	41
R50-RTOP-TT-126541-US2-L	-L or -R	916	1,022	2	12	65	41
R50-RTOP-TT-126841-US2-L	-L or -R	916	1,022	2	12	68	41
R50-RTOP-TT-127141-US2-L	-L or -R	916	1,022	2	12	71	41
R50-RTOP-TT-127441-US2-L	-L or -R	921	1,027	2	12	74	41
R50-RTOP-TT-127741-US2-L	-L or -R	921	1,027	2	12	77	41
R50-RTOP-TT-128041-US2-L	-L or -R	921	1,027	2	12	80	41
R50-RTOP-TT-128341-US2-L	-L or -R	921	1,027	2	12	83	41
R50-RTOP-TT-128641-US3-L	-L or -R	1,026	1,132	2	12	86	41
R50-RTOP-TT-128941-US3-L	-L or -R	1,257	1,363	2	12	89	41
R50-RTOP-TT-129241-US3-L	-L or -R	1,257	1,363	2	12	92	41
R50-RTOP-TT-129541-US3-L	-L or -R	1,257	1,363	2	12	95	41

Grain runs side to side on these return transaction tops

RETURN RTOP TRANSACTION TOPS

VERTICAL SUPPORTS AT 'WIDE' SPACING

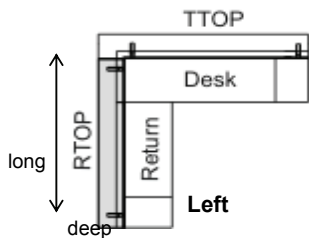
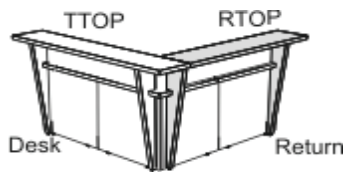
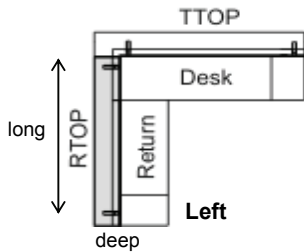
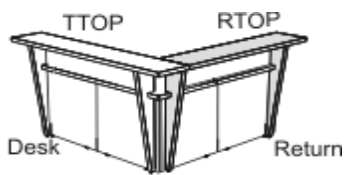

Add a RTOP RETURN Transaction Top to the R50 return with WIDE vertical spacing

		WPE	STD	RTOP size			
				verts	deep	long	high
R50-RTOP-TT-122141-W-FB	-L or -R	681	787	1	12	21	41
R50-RTOP-TT-122441-W-FB	-L or -R	681	787	1	12	24	41

R50-RTOP-TT-124441-W-FB	-L or -R	754	860	2	12	44	41
R50-RTOP-TT-124741-W-FB	-L or -R	754	860	2	12	47	41
R50-RTOP-TT-125041-W-FB	-L or -R	878	984	2	12	50	41
R50-RTOP-TT-125341-W-FB	-L or -R	878	984	2	12	53	41
R50-RTOP-TT-125641-W-FB	-L or -R	878	984	2	12	56	41
R50-RTOP-TT-125941-W-FB	-L or -R	878	984	2	12	59	41

Grain runs from Front to Back on the 'FB' return transaction tops

Add a RTOP RETURN Transaction Top to the R50 return with WIDE vertical spacing

		WPE	STD	RTOP size			
				verts	deep	long	high
R50-RTOP-TT-122041-UW2	-L or -R	681	787	2	12	20	41
R50-RTOP-TT-122341-UW2	-L or -R	681	787	2	12	23	41

R50-RTOP-TT-124441-UW2	-L or -R	754	860	2	12	44	41
R50-RTOP-TT-124741-UW2	-L or -R	754	860	2	12	47	41
R50-RTOP-TT-125041-UW2	-L or -R	878	984	2	12	50	41
R50-RTOP-TT-125341-UW2	-L or -R	878	984	2	12	53	41
R50-RTOP-TT-125641-UW3	-L or -R	878	984	3	12	56	41
R50-RTOP-TT-125941-UW3	-L or -R	878	984	3	12	59	41
R50-RTOP-TT-126241-UW3	-L or -R	916	1,022	3	12	62	41
R50-RTOP-TT-126541-UW3	-L or -R	916	1,022	3	12	65	41
R50-RTOP-TT-126841-UW3	-L or -R	916	1,022	3	12	68	41
R50-RTOP-TT-127141-UW3	-L or -R	916	1,022	3	12	71	41
R50-RTOP-TT-127441-UW3	-L or -R	921	1,027	3	12	74	41
R50-RTOP-TT-127741-UW3	-L or -R	921	1,027	3	12	77	41
R50-RTOP-TT-128041-UW3	-L or -R	921	1,027	3	12	80	41
R50-RTOP-TT-128341-UW3	-L or -R	921	1,027	3	12	83	41
R50-RTOP-TT-128641-UW3	-L or -R	1,026	1,132	3	12	86	41
R50-RTOP-TT-128941-UW3	-L or -R	1,257	1,363	3	12	89	41
R50-RTOP-TT-129241-UW3	-L or -R	1,257	1,363	3	12	92	41
R50-RTOP-TT-129541-UW3	-L or -R	1,257	1,363	3	12	95	41

Grain runs side to side on these return transaction tops

DEEPER RECEPTION 50 DESKS - Rectangles - depth is increased by 3"

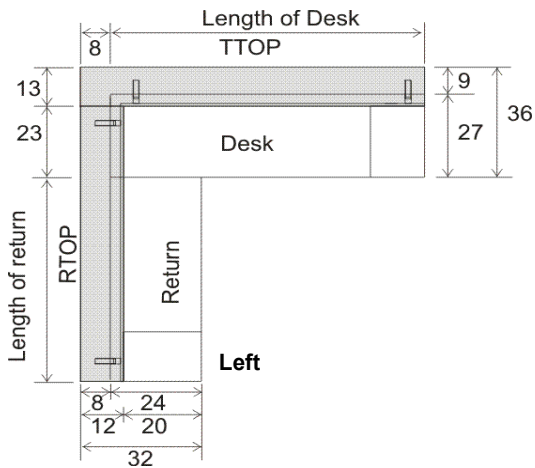

The 27" deep rectangle desk increases the depth of the desk by 3"
 The RTOP return transaction top used with either a return or bridge, overhangs the desk by 23".
 Use the 24" deep pedestals and cabinets with these desks.

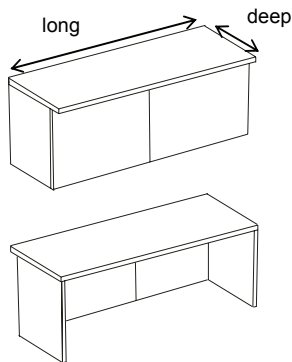

Model Number	List Price with two end panels		Footprint			Wgt
	WPE	STD	deep	long	high	
R50-D-TT-274829	1,595	1,701	27	48	29	
R50-D-TT-275429	1,731	1,837	27	54	29	
R50-D-TT-276029	1,731	1,837	27	60	29	
R50-D-TT-276629	1,958	2,064	27	66	29	
R50-D-TT-277229	1,958	2,064	27	72	29	
R50-D-TT-277829	2,238	2,344	27	78	29	
R50-D-TT-278429	2,238	2,344	27	84	29	
R50-D-TT-279029	2,354	2,460	27	90	29	
R50-D-TT-279629	2,539	2,645	27	96	29	
R50-D-TT-2710229	2,905	3,011	27	102	29	
R50-D-TT-2710829	2,905	3,011	27	108	29	
R50-D-TT-2711429	2,905	3,011	27	114	29	
R50-D-TT-2712029	2,905	3,011	27	120	29	

Use the 24" deep pedestals and cabinets with these desks

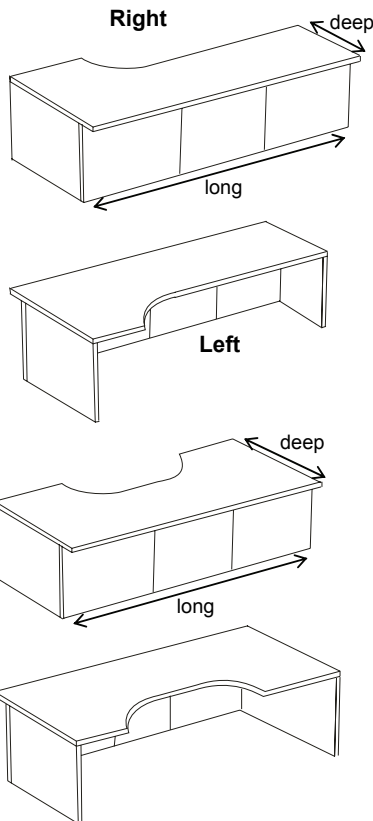

Model Number	List Price with two end panels		Footprint			Wgt
	WPE	STD	deep	long	high	
R50-D-TT-457229-IR	-L or -R	2,656	2,762	45	72	29
R50-D-TT-457829-IR	-L or -R	3,039	3,145	45	78	29
R50-D-TT-458429-IR	-L or -R	3,039	3,145	45	84	29
R50-D-TT-459029-IR	-L or -R	3,168	3,274	45	90	29
R50-D-TT-459629-IR	-L or -R	3,353	3,459	45	96	29
R50-D-TT-4510229-IR	-L or -R	3,804	3,910	45	102	29
R50-D-TT-4510829-IR	-L or -R	3,804	3,910	45	108	29
R50-D-TT-4511429-IR	-L or -R	3,804	3,910	45	114	29
R50-D-TT-4512029-IR	-L or -R	3,804	3,910	45	120	29

Use the 24" deep pedestals and cabinets with these desks

Model Number	WPE	STD	deep	long	high	Wgt
R50-D-TT-458429-DIR	3,490	3,596	45	84	29	
R50-D-TT-459029-DIR	3,619	3,725	45	90	29	
R50-D-TT-459629-DIR	3,804	3,910	45	96	29	
R50-D-TT-4510229-DIR	4,255	4,361	45	102	29	
R50-D-TT-4510829-DIR	4,255	4,361	45	108	29	
R50-D-TT-4511429-DIR	4,255	4,361	45	114	29	
R50-D-TT-4512029-DIR	4,255	4,361	45	120	29	

Use the 24" deep pedestals and cabinets with these desks

DEEPER RECEPTION 50 DESKS - Bow Front - depth is increased by 3"

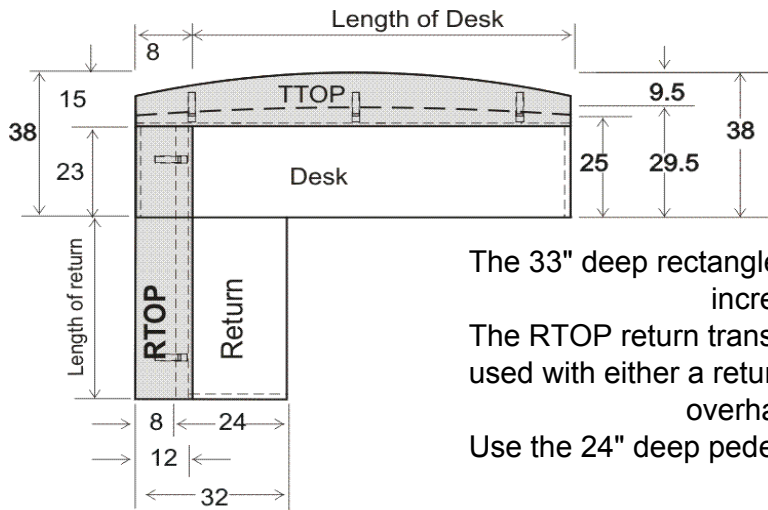

The 33" deep rectangle desk
increases the depth of the desk by 3"
The RTOP return transaction top
used with either a return or bridge,
overhangs the desk by 23".
Use the 24" deep pedestals and cabinets with these desks.

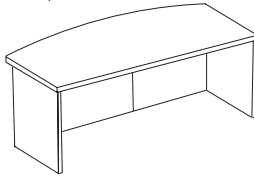
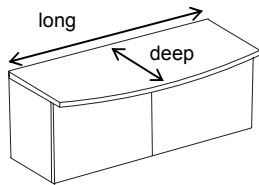

Right

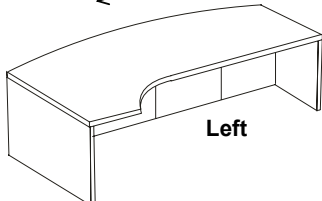
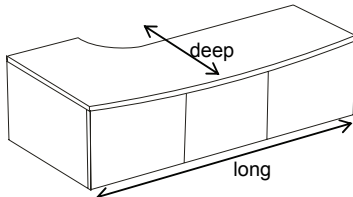

Left

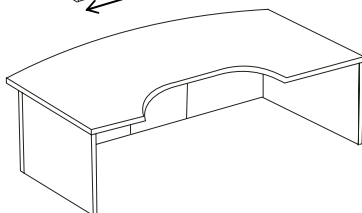
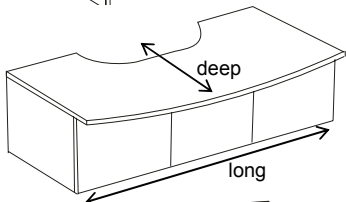

List Price with two end panels

Model Number	List Price with two end panels		Footprint			Wgt
	WPE	STD	deep	long	high	
R50-D-BO-304829	1,994	2,100	29.5	48	29	
R50-D-BO-305429	2,091	2,197	29.5	54	29	
R50-D-BO-306029	2,091	2,197	29.5	60	29	
R50-D-BO-306629	2,290	2,396	29.5	66	29	
R50-D-BO-307229	2,297	2,403	29.5	72	29	
R50-D-BO-307829	2,671	2,777	29.5	78	29	
R50-D-BO-308429	2,671	2,777	29.5	84	29	
R50-D-BO-309029	2,790	2,896	29.5	90	29	
R50-D-BO-309629	2,975	3,081	29.5	96	29	
R50-D-BO-3010229	3,406	3,512	29.5	102	29	
R50-D-BO-3010829	3,406	3,512	29.5	108	29	
R50-D-BO-3011429	3,406	3,512	29.5	114	29	
R50-D-BO-3012029	3,406	3,512	29.5	120	29	

Use the 24" deep pedestals and cabinets with these desks

R50-D-BO-487229-IR	-L or -R	2,926	3,032	47.5	72	29
R50-D-BO-487829-IR	-L or -R	3,300	3,406	47.5	78	29
R50-D-BO-488429-IR	-L or -R	3,300	3,406	47.5	84	29
R50-D-BO-489029-IR	-L or -R	3,419	3,525	47.5	90	29
R50-D-BO-489629-IR	-L or -R	3,604	3,710	47.5	96	29
R50-D-BO-4810229-IR	-L or -R	4,035	4,141	47.5	102	29
R50-D-BO-4810829-IR	-L or -R	4,035	4,141	47.5	108	29
R50-D-BO-4811429-IR	-L or -R	4,035	4,141	47.5	114	29
R50-D-BO-4812029-IR	-L or -R	4,035	4,141	47.5	120	29

Use the 24" deep pedestals and cabinets with these desks

R50-D-BO-488429-DIR		3,868	3,974	47.5	84	29
R50-D-BO-489029-DIR		3,997	4,103	47.5	90	29
R50-D-BO-489629-DIR		4,182	4,288	47.5	96	29
R50-D-BO-4810229-DIR		4,633	4,739	47.5	102	29
R50-D-BO-4810829-DIR		4,633	4,739	47.5	108	29
R50-D-BO-4811429-DIR		4,633	4,739	47.5	114	29
R50-D-BO-4812029-DIR		4,633	4,739	47.5	120	29

Use the 24" deep pedestals and cabinets with these desks

DEEPER RECEPTION 50 DESKS - Trapezoids - depth is increased by 3"

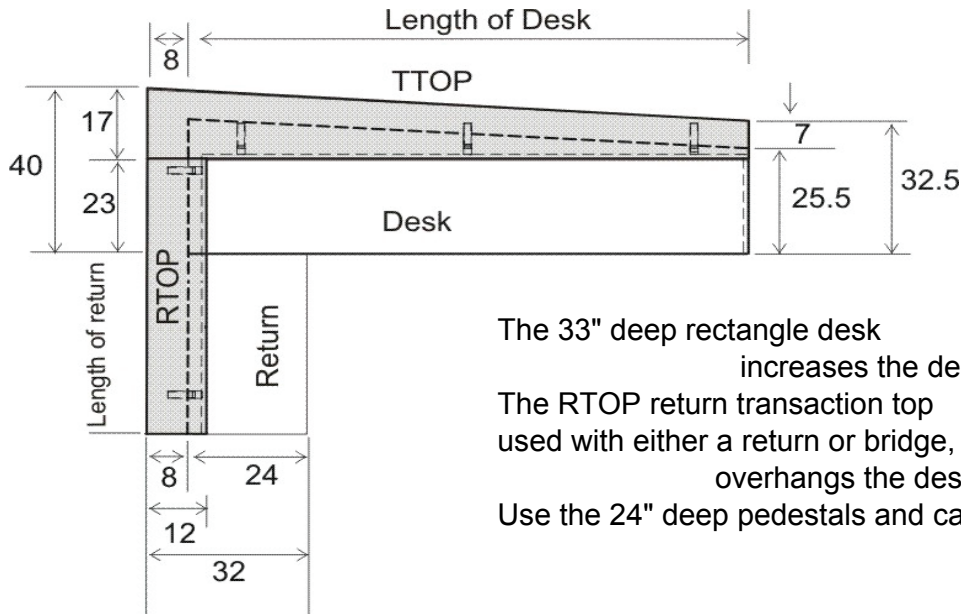

The 33" deep rectangle desk increases the depth of the desk by 3"
 The RTOP return transaction top used with either a return or bridge, overhangs the desk by 23".
 Use the 24" deep pedestals and cabinets with these desks.

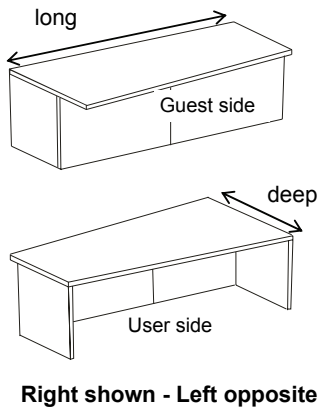

Model Number	List Price with two end panels		Footprint			
	WPE	STD	deep	long	high	Wgt
R50-D-TZ-334829	-L or -R	1,763	1,869	33	48	29
R50-D-TZ-335429	-L or -R	1,860	1,966	33	54	29
R50-D-TZ-336029	-L or -R	1,860	1,966	33	60	29
R50-D-TZ-336629	-L or -R	2,059	2,165	33	66	29
R50-D-TZ-337229	-L or -R	2,066	2,172	33	72	29
R50-D-TZ-337829	-L or -R	2,440	2,546	33	78	29
R50-D-TZ-338429	-L or -R	2,440	2,546	33	84	29
R50-D-TZ-339029	-L or -R	2,559	2,665	33	90	29
R50-D-TZ-339629	-L or -R	2,744	2,850	33	96	29
R50-D-TZ-3310229	-L or -R	3,175	3,281	33	102	29
R50-D-TZ-3310829	-L or -R	3,175	3,281	33	108	29
R50-D-TZ-3311429	-L or -R	3,175	3,281	33	114	29
R50-D-TZ-3312029	-L or -R	3,175	3,281	33	120	29

Use the 24" deep pedestals and cabinets with these desks

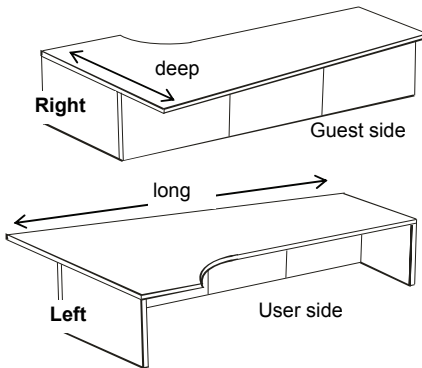

R50-D-TZ-517229-IR	-L or -R	2,811	2,917	51	72	29
R50-D-TZ-517829-IR	-L or -R	3,185	3,291	51	78	29
R50-D-TZ-518429-IR	-L or -R	3,185	3,291	51	84	29
R50-D-TZ-519029-IR	-L or -R	3,304	3,410	51	90	29
R50-D-TZ-519629-IR	-L or -R	3,489	3,595	51	96	29
R50-D-TZ-5110229-IR	-L or -R	3,920	4,026	51	102	29
R50-D-TZ-5110829-IR	-L or -R	3,920	4,026	51	108	29
R50-D-TZ-5111429-IR	-L or -R	3,920	4,026	51	114	29
R50-D-TZ-5112029-IR	-L or -R	3,920	4,026	51	120	29

Use the 24" deep pedestals and cabinets with these desks

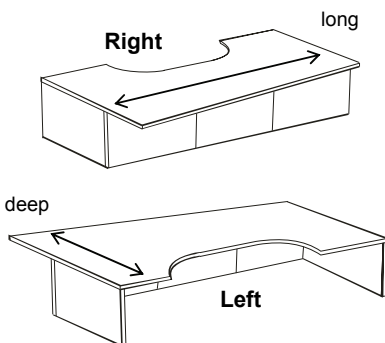

R50-D-TZ-518429-DIR	-L or -R	3,868	3,974	51	84	29
R50-D-TZ-519029-DIR	-L or -R	3,997	4,103	51	90	29
R50-D-TZ-519629-DIR	-L or -R	4,182	4,288	51	96	29
R50-D-TZ-5110229-DIR	-L or -R	4,633	4,739	51	102	29
R50-D-TZ-5110829-DIR	-L or -R	4,633	4,739	51	108	29
R50-D-TZ-5111429-DIR	-L or -R	4,633	4,739	51	114	29
R50-D-TZ-5112029-DIR	-L or -R	4,633	4,739	51	120	29

Use the 24" deep pedestals and cabinets with these desks

SERIES 50 Bridge, rectangular top: CR

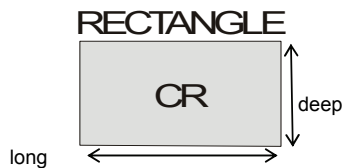

	Deep	Long	Top	Edge	Profile	Grain	MP	Wt	WPE List
S50-B-	24	30	CR-					29	267
S50-B-	24	36	CR-					34	280
S50-B-	24	42	CR-					39	293
S50-B-	24	48	CR-				MP	44	452
S50-B-	24	54	CR-				MP	49	465
S50-B-	24	60	CR-				MP	54	479
MP Modesty Panel, vertical grain, is included on 48" and longer for 30", 36", 42" lengths,								add	159
GRC								add	46

Bridge top connects at 24 end to corner unit or desk

S2S = grain runs side to side
F2B = grain runs front to back

SERIES 50 CREDENZAS - when a RTOP return transaction top is not needed

Top edge	WPE, STD	Pricing is for WPE WoodPlus edge, upcharge for STD 3mm wood edge, per top	add	106
Edge profile	SM. RE. NEO	SM smooth profile, RE Reeded profile, NEO Neoclassic profile		
Modesty Panel	MP	MP Modesty Panel is available	add	169
Pull		Choose pull style for the lower drawers: 10, 12, 13, 14, 15, 18, 19		

Credenza with single pedestal, locked

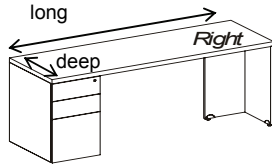
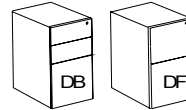

Sizes available for CR tops

Model	Deep	Long	Top	Edge	Profile	Ped	Pull	L / R	Wt	WPE List
S50-CR-	24	60	CR-						156	1,225
S50-CR-	24	66	CR-						161	1,244
S50-CR-	24	72	CR-						166	1,263

Credenza with single cabinet, locked

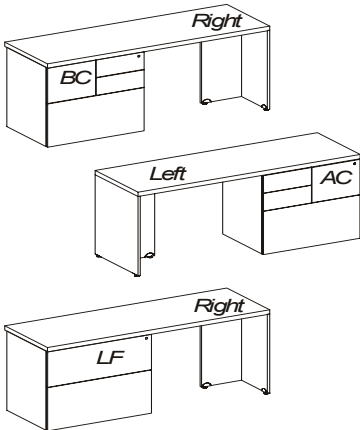

Combo Cabinets are 32" wide
Lateral Files are 36" wide on 60, 66, 72" sizes

Sizes available for CR tops

Model	Deep	Long	Top	Edge	Profile	Cab	Pull	L / R	Wt	WPE List
S50-CR-	24	60	CR-						216	1,561
S50-CR-	24	66	CR-						221	1,580
S50-CR-	24	72	CR-						226	1,599
MP Modesty Panel, horizontal grain									add	159
GRE grommet available at panel end of top, centered front to back									add	46

SERIES 50 CREDENZAS - when a RTOP return transaction top is not eeded

Top edge	WPE, STD	Pricing is for WPE WoodPlus edge, upcharge for STD 3mm wood edge, per top	add	106
Edge profile	SM, RE, NEO	SM smooth profile, RE Reeded profile, NEO Neoclassic profile		
Modesty Panel	MP	MP Modesty Panel is available	add	169
Pull		Choose pull style for the lower drawers: 10, 12, 13, 14, 15, 18, 19	add	169

Top shapes available on S50-CR models

RECTANGLE



Locking pedestal with top

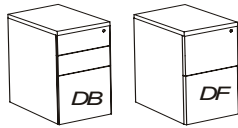

Model	Deep	Long	Top	Edge	Profile	Ped	Pull	Wt	WPE List
S50-CR-	24	16	CR-					95	954
Includes worksurface top.									

Credenza with double pedestals, locked

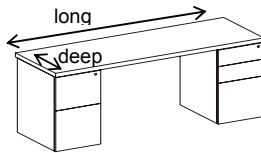

Model	Deep	Long	Top	Edge	Profile	Ped Left	Ped Right	Pull	Wt	WPE List
S50-CR-	24	60	CR-						214	1,758
S50-CR-	24	66	CR-						219	1,777
S50-CR-	24	72	CR-						224	1,796
MP Modesty Panel, horizontal grain									add	159
GRC Center Grommet available									add	46

Credenza filled with double pedestals, locked and door storage

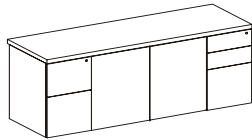

Model	Deep	Long	Top	Edge	Profile	Ped Left	DS	Ped Right	Wt	WPE List
S50-CR-	24	60	CR-				DS-		339	2,516
S50-CR-	24	66	CR-				DS-		352	2,535
S50-CR-	24	72	CR-				DS-		372	2,554
MP Modesty Panel, horizontal grain									add	159
Optional lock available for DS Door Storage									add	83

Credenza filled with file cabinets, locked

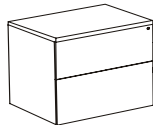

Model	Deep	Long	Top	Edge	Profile	Cab	Pull	Wt	List
S50-CR-	24	30	CR-			LF		167	1,305
S50-CR-	24	36	CR-			LF		172	1,318
Includes one lateral file cabinet for a total of two lateral file drawers									

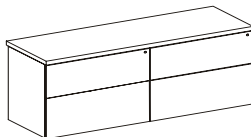

Model	Deep	Long	Top	Edge	Profile	Cab1	Cab2	Pull	Wt	WPE List
S50-CR-	24	60	CR-			LF	LF		334	2,430
S50-CR-	24	72	CR-			LF	LF		202	2,468
MP Modesty Panel, horizontal grain									add	159
Includes two lateral file cabinets for a total of four lateral file drawers										

SERIES 50 RETURN- use when a RTOP return transaction top is not needed

RECTANGLE RETURNS

LEFT
To the left of user
when seated at desk

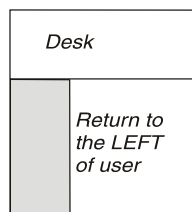

RIGHT
To the right of user
when seated at desk

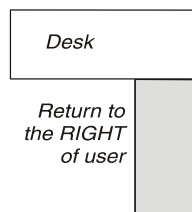

Grain ●
S2S = grain runs
side to side
F2B = grain runs
front to back

Top edge	WPE, STD	Pricing is for WPE WoodPlus edge, upcharge for STD 3mm wood edge, per top	STD add	106
Edge profile	SM, RE, NEO	SM smooth profile, RE Reeded profile, NEO Neoclassic profile		
Grain	S2S, F2B	Grain on return is S2S side to side or F2B front to back		
Modesty Panel	MP	MP Modesty Panel is available	add	169
Pull		Choose pull style for the lower drawers: 10, 12, 13, 14, 15, 18, 19		

Returns, no storage

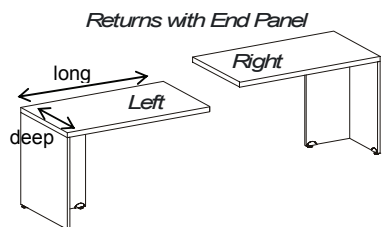

	Deep	Long	Top	Edge	Profile	L/R	Grain	Wt	List
S50-R-	24	30	CR-					51	453
S50-R-	24	36	CR-					56	466
S50-R-	24	42	CR-					61	479
S50-R-	24	48	CR-					66	479
S50-R-	24	54	CR-					71	492
S50-R-	24	60	CR-					76	506
								add	159
								add	46

Returns, single pedestal locked

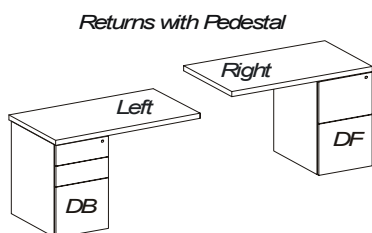

	Deep	Long	Top	Edge	Profile	Ped	Pull	L/R	Wt	List	WPE
S50-R-	24	30	CR-						109	986	
S50-R-	24	36	CR-						114	999	
S50-R-	24	42	CR-						119	1,012	
S50-R-	24	48	CR-						124	1,012	
S50-R-	24	54	CR-						129	1,025	
S50-R-	24	60	CR-						134	1,039	
S50-R-	24	66	CR-						139	1,058	
S50-R-	24	72	CR-						142	1,060	
									add	159	

Returns, single cabinet locked

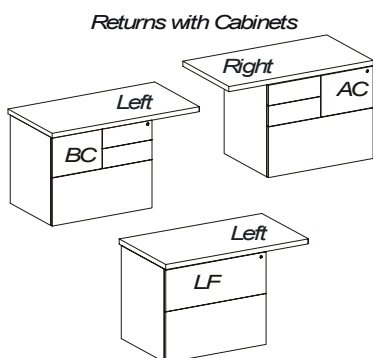

	Deep	Long	Top	Edge	Profile	Cab	Pull	L/R	Wt	List	WPE
S50-R-	24	36	CR-						174	1,335	
S50-R-	24	42	CR-						179	1,348	
S50-R-	24	48	CR-						184	1,348	
S50-R-	24	54	CR-						189	1,361	
S50-R-	24	60	CR-						194	1,375	
S50-R-	24	66	CR-						199	1,394	
S50-R-	24	72	CR-						204	1,413	
									add	159	

MP Modesty Panel, horizontal grain

Combo cabinets are 32" wide.

Lateral files: 36" long returns use LF30, 42" and longer use LF36.

TRANSACTION TOP AND DESK TOP EDGES

Applied Edge Profiles

Transaction Top edge or Desk top edge
WoodPlus Edge Profiles - all are 3mm thick

WPE
3mm PVC

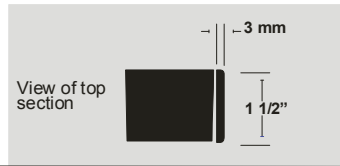

Tops are
1 1/2" thick



WPEFS
WoodPlus
Smooth



WPEFR
WoodPlus
Reeded



WPEFN
WoodPlus
Neo Classic

Transaction Top edge or Desk top edge
Wood Edge Profiles - all are 3mm thick

STD
3mm
Hardwood

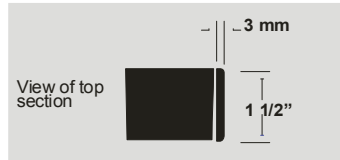

Tops are
1 1/2" thick

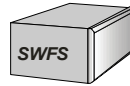

SWFS
Wood edge
Smooth



SWFR
Wood edge
Reeded

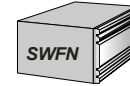

SWFN
Wood edge
Neo Classic

Transaction Top edge - on all four sides
Wood Edge Profiles - all are 3mm thick

ALUM
3mm
Aluminum

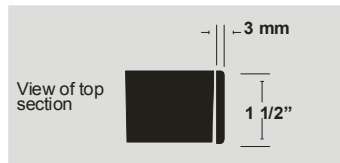

Tops are
1 1/2" thick



ALFS
Aluminum
edge smooth



ALFW
Aluminum
edge swirled

TRANSACTION TOP EDGES

Transaction Top edge - on all four sides
Detailed Wood Edges - all are 3/8" thick

DET
3/8"
Hardwood

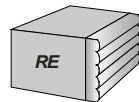
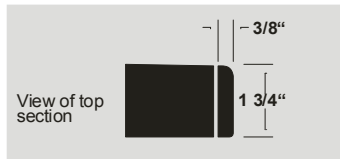

RE
Reeded

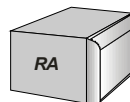

RA
Radius

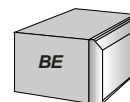

BE
Beveled

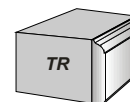

TR
Transitional

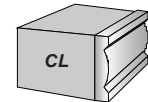

CL
Classic

Transaction Top 'guest side' edge
2000 Wood edge - all are 1 3/4" thick

2000
3/4" to 2"
Hardwood

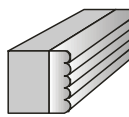
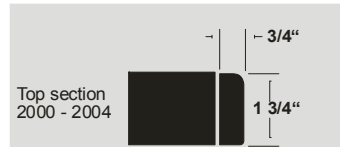

2000

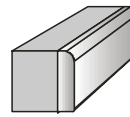

2001

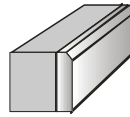

2002

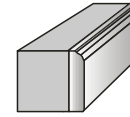

2003

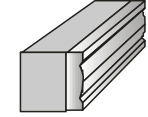

2004

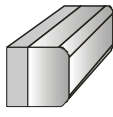
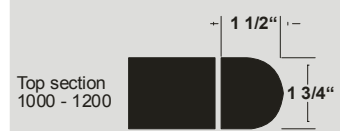

1000

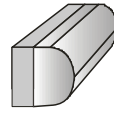

1100

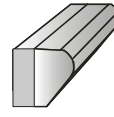

1200

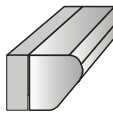
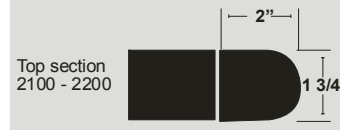

2200

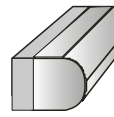

2100

Transaction Top edge
3000 Wood edge

3000
3"
Hardwood

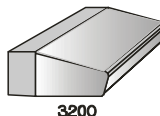
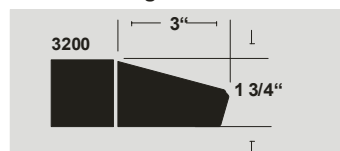

3200

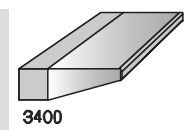
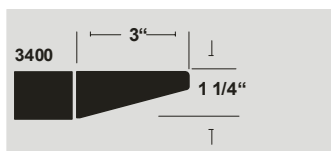

3400

TRANSACTION TOP AND DESK TOP EDGES

The 2000 Series and 3000 Series wood edges are only applied along the guest side of the Transaction Top

Edge	List Charge
R50-TTOP-1EDGE-2000-BOW	353
R50-TTOP-1EDGE-3000-BOW	509
R50-TTOP-1EDGE-2000-TT	353
R50-TTOP-1EDGE-3000-TT	509
R50-TTOP-1EDGE-2000-TZ	353
R50-TTOP-1EDGE-3000-TZ	509

The Detailed wood edge and the Aluminum edges are applied on all four sides of the Transaction Top

R50-TTOP-4EDGE-DET-BOW	277
R50-TTOP-4EDGE-DET-TT	277
R50-TTOP-4EDGE-DET-TZ	277
R50-TTOP-4EDGE-ALUM-BOW	554
R50-TTOP-4EDGE-ALUM-TT	554
R50-TTOP-4EDGE-ALUM-TZ	554

Transaction top inlays - Black, Satin Chrome, Brushed Brass.
Examples shown on right:

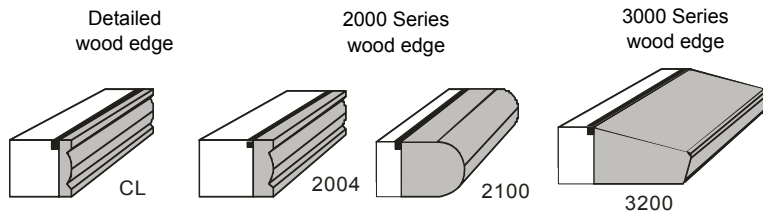

The 2000 Series and 3000 Series wood edges use these INLAY charges. The INLAY is only applied along the guest side of the Transaction Top

INLAY on guest side	List Charge
R50-TTOP-INLAY1-BLACK-BOW	95
R50-TTOP-INLAY1-BRASS-BOW	137
R50-TTOP-INLAY1-CHROME-BOW	137
R50-TTOP-INLAY1-BLACK-TT	95
R50-TTOP-INLAY1-BRASS-TT	137
R50-TTOP-INLAY1-CHROME-TT	137
R50-TTOP-INLAY1-BLACK-TZ	95
R50-TTOP-INLAY1-BRASS-TZ	137
R50-TTOP-INLAY1-CHROME-TZ	137

The Detailed wood edge uses these INLAY charges. The INLAY is applied on all four sides of the Transaction Top

INLAY on all four sides	List Charge
R50-TTOP-INLAY4-BLACK-BOW	380
R50-TTOP-INLAY4-BRASS-BOW	548
R50-TTOP-INLAY4-CHROME-BOW	548
R50-TTOP-INLAY4-BLACK-TT	380
R50-TTOP-INLAY4-BRASS-TT	548
R50-TTOP-INLAY4-CHROME-TT	548
R50-TTOP-INLAY4-BLACK-TZ	380
R50-TTOP-INLAY4-BRASS-TZ	548
R50-TTOP-INLAY4-CHROME-TZ	548

OPTIONS AND ACCESSORIES

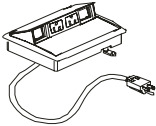
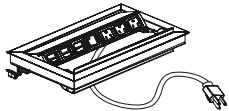
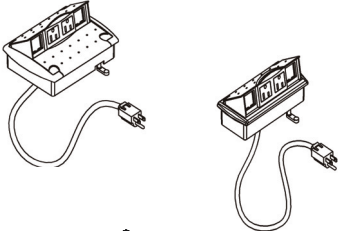
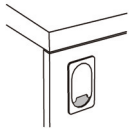

LIST

OPTION-GRL	48	Grommet in the Left back corner when seated at desk
OPTION-GRC	48	Grommet in the Center back when seated at desk
OPTION-GRR	48	Grommet in the Right back corner when seated at desk

OPTION-GRVL	48	Grommet in the Left end of unit when seated at desk
OPTION-GRVC	48	Grommet in the Center back when seated at desk
OPTION-GRVR	48	Grommet in the Right end when seated at desk

INTERPORT-PLUG	236	
MINI-PORT-PLUG	197	

MINI-ACT-3-4-120-PLUG	493	
-----------------------	-----	--

MINI-ACT-2-2-120-PLUG	396	
-----------------------	-----	--

RJ45 data - category 6	INSERT-MA-CAT6-RJ45-S68	28
RJ45 data - category 5	INSERT-MA-CAT5-RJ45-S58	17
RJ25 phone	INSERT-MA-PHONE-RJ25-S6U	15
SVHS video jack	INSERT-MA-VIDEO-1SVHS	18
RCA audio jack	INSERT-MA-AUDIO-RCA	15

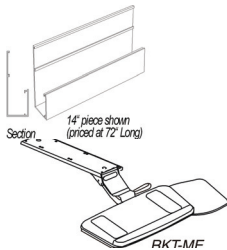

MJT-MP	66	
--------	----	--

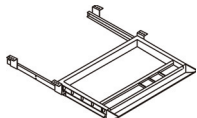

RKT-ME	263	
--------	-----	--

CDM-21	44	
--------	----	--

FILLERS AND ACCENTS

	WPE	STD	
R50-FILLER-WP	184	184	fits between one pair of uprights
R50-FILLER-WP2	220	220	fits between one pair of uprights
R50-FILLER-METAL	444	444	fits between one pair of uprights

R50-ACCENT-WP	184	184	fits between one pair of uprights
R50-ACCENT-WP2	440	440	fits between one pair of uprights
R50-ACCENT-METAL	560	560	fits between one pair of uprights

END PANELS, FRONT MODESTY PANELS, PEDESTALS, CABINETS

	List	
	WPE	STD
R50-EP-1229-GABLE	276	276
R50-EP-1229-L	276	276
R50-EP-1229-R	276	276
R50-EP-2129-L	336	336
R50-EP-2129-R	336	336
R50-EP-2429-L	336	336
R50-EP-2429-R	336	336
R50-EP-3029-L	360	360
R50-EP-3029-R	360	360
R50-EP-3629-L	386	386
R50-EP-3629-R	386	386
R50-EP-4229-L	409	409
R50-EP-4229-R	409	409
R50-EP-4529-L	432	432
R50-EP-4529-R	432	432
R50-EP-4829-L	455	455
R50-EP-4829-R	455	455

	List	
	WPE	STD
Pedestals at 21" deep		
R50-PED-DB-1621-LOCK	780	780
R50-PED-DB-1630-LOCK	780	780
R50-PED-DF-1621-LOCK	780	780
R50-PED-DF-1630-LOCK	780	780

	List	
	WPE	STD
Cabinets at 21" deep		
R50-CAB-LF-3021-LOCK	1,136	1,136
R50-CAB-AC-3221-LOCK	1,136	1,136
R50-CAB-BC-3221-LOCK	1,136	1,136
R50-CAB-LF-3621-LOCK	1,136	1,136

	List	
	WPE	STD
Pedestals at 24" deep		
R50-PED-DB-1624-LOCK	780	780
R50-PED-DB-1630-LOCK	780	780
R50-PED-DF-1624-LOCK	780	780
R50-PED-DF-1630-LOCK	780	780

	List	
	WPE	STD
Cabinets at 24" deep		
R50-CAB-LF-3024-LOCK	1,136	1,136
R50-CAB-AC-3224-LOCK	1,136	1,136
R50-CAB-BC-3224-LOCK	1,136	1,136
R50-CAB-LF-3624-LOCK	1,136	1,136

	List	
	WPE	STD
Front panels on desks, returns		
R50-MP-2429-VERT	185	185
R50-MP-2729-VERT	185	185
R50-MP-3029-VERT	185	185
R50-MP-3229-VERT	185	185
R50-MP-3329-VERT	185	185
R50-MP-3429-VERT	185	185
R50-MP-3629-VERT	185	185
R50-MP-3929-VERT	185	185
R50-MP-4029-VERT	185	185
R50-MP-4229-VERT	185	185
R50-MP-4529-VERT	185	185
R50-MP-4829-VERT	185	185
R50-MP-5129-VERT	185	185
R50-MP-5429-VERT	185	185
R50-MP-5729-VERT	185	185
R50-MP-6029-VERT	185	185

